

Solar module mounting instructions

Mono S5 / Mono S4 / Mono S3



Creating a Powerful Future

Table of contents

1. Validity	3
2. Safety instructions	4
General safety instructions	4
Applicable safety regulations.....	4
Using the modules	4
Electrical installation	5
Transport, intermediate storage and safe unpacking.....	5
3. Installation of the module	6
Ensuring safe installation	6
comply with the maximum permissible mechanical load.....	6
Ensuring that the modules are properly earthed.....	6
Correct handling of AR glass modules	7
Technical explanation of the cell production process of a solar module	8
Ensure comprehensive fire protection.....	8
Pay attention to an appropriate environment.....	8
Ensure the suitable installation situation	8
Choose the correct mounting location	8
Secure yield through optimal orientation and tilt.....	8
Avoiding permanent shading of solar modules	9
Excluding hotspots	9
Instructions for installation	10
Load capacities	10
Mounting-Variants standard modules Test load 2400 Pa / -1600 Pa.....	11
Mounting-Variants standard modules Load capacity 3600 Pa / -2400 Pa	12
Mounting-Variants standard modules Load capacity 5400 Pa / -3600 Pa	12
Mounting-Variants standard modules Load capacity 8100 Pa / -5400 Pa	13
Mounting-Variants project modules Load capacity 1600 Pa / -800 Pa.....	14
Mounting-Variants project modules Load capacity 1600 Pa / -1200 Pa.....	14
Mounting-Variants project modules Load capacity 2400 Pa / -1600 Pa.....	15
Proper cabling	16
Ensure correct wiring	16
Using suitable materials only	16
Maintenance and cleaning	17
Instructions for disassembly -> Shut down!.....	18
Disposal of the modules.....	18

Solar module mounting instructions

Mono S5 / Mono S4 / Mono S3

1. Validity

- + Mono S5 88 triplecut cells
- + Mono S5 60 half cells

- + Mono S4 96 half cells
- + Mono S4 108 half cells
- + Mono S4 120 half cells
- + Mono S4 132 half cells
- + Mono S4 144 half cells
- + Mono S4 156 half cells

- + Mono S3 120 half cells
- + Mono S3 120 bifacial half cells
- + Mono S3 144 half cells

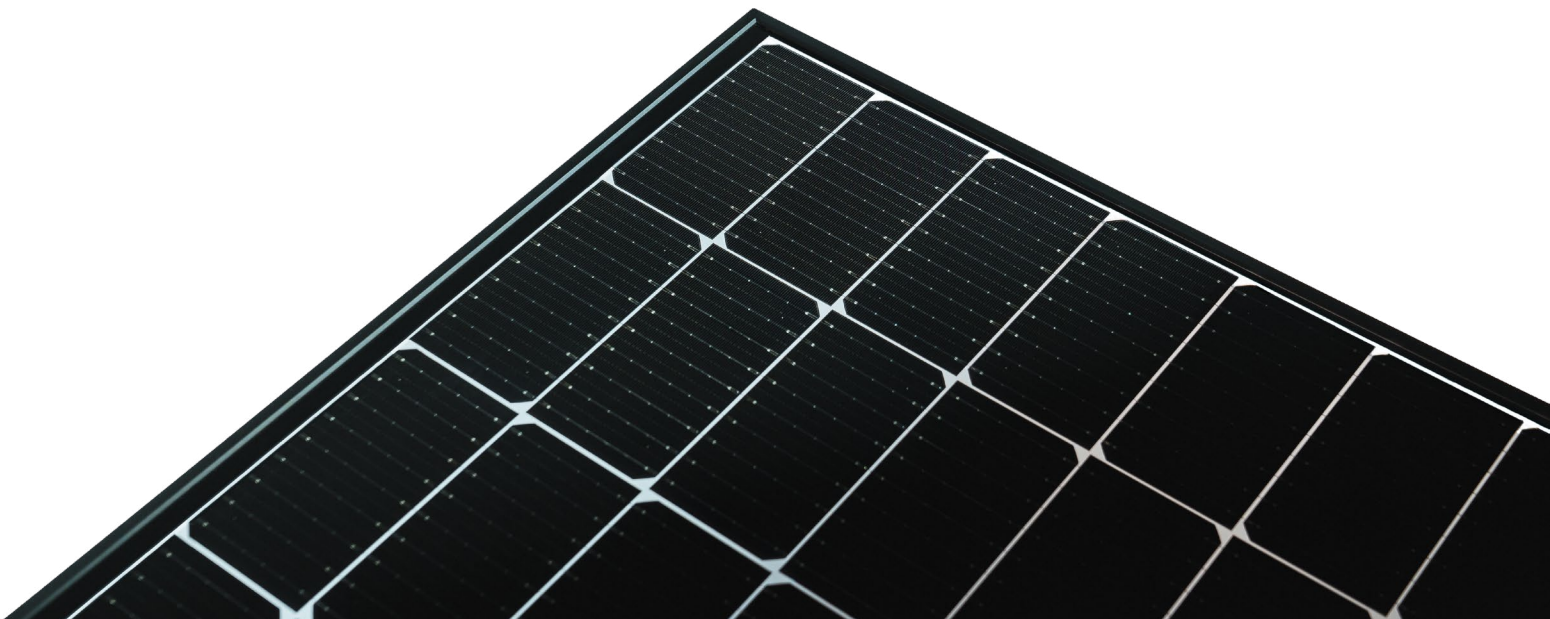

Solar module mounting instructions

Mono S5 / Mono S4 / Mono S3

2. Safety instructions

General safety instructions

Repair and operation of a PV system require sound expert knowledge. Therefore, all work on the system may only be carried out by appropriately qualified and authorised technical specialists. It is essential to read these mounting instructions carefully and attentively before installing, commissioning or maintaining the PV system, and keep the instructions easily accessible. Non-observance of the safety instructions can lead to personal injury and damage to property. Keep children away!

We are constantly striving for the further improvement of our products through innovation and research activity.

We therefore reserve the right to change the information contained in this mounting manual without prior notice.

Applicable safety regulations

The modules of the system may only be used in accordance with their suitability. The modules may not be technically modified. During mounting, make sure that the locally applicable building regulations, standards and accident prevention regulations are observed. Ensure that the necessary safety instructions for mounting and operation of other system components are also followed.

Using the modules

Please note the following points in particular when using our solar modules:

- + The installation and/or operation of the solar modules is permitted up to a max. altitude of 2000 m above sea level.
- + The function of the modules is tested at an ambient temperature of -40 to +85°C. This range should be observed.
- + The modules must not be exposed to exceptional chemical loads (e.g. emissions from manufacturing companies).
- + When connecting solar modules to power storage units, the respective safety instructions of the manufacturer must be observed.

Attention: Danger to life!

Solar modules generate electricity. If they are exposed to light, they are live and can pose a danger. Even if the voltage of a single module is still low at less than 50 V DC, the total voltage adds up as soon as several modules are connected in series.

When several modules are connected in parallel, the currents add up. Although the fully insulated plug contacts provide protection against accidental contact, the following must be observed when handling the solar modules to avoid fire, sparking and, above all, fatal electric shock:

- + Do not insert electrically conductive parts into plugs and sockets!
- + Avoid wearing metallic jewelry during mechanical and electrical installation work!
- + Keep moisture away from tools and the work environment! Only assemble solar modules and cables using dry plugs and sockets!
- + Proceed with utmost caution and care! Perform all work on cables using insulated tools, and wear additional insulating gloves!
- + Do not disassemble modules! Do not remove manufacturer-installed components or labels under any circumstances! Use only undamaged modules! Do not treat the back of the module with sharp objects, paint, or adhesives!
- + Do not expose solar modules to artificially concentrated sunlight.

Please note that the wiring of modules may only be carried out by qualified and authorised specialists.

Solar module mounting instructions

Mono S5 / Mono S4 / Mono S3

Danger to life due to high voltage!

High contact voltages can still occur in the inverter even when it is disconnected. For this reason, the following applies

- + Exercise extreme caution when working on the inverter and the cables.
- + In order for the high-voltage components to discharge, it is essential to observe the time intervals specified by the inverter manufacturer after switching off the inverter and before starting any further work. Always observe the mounting instructions of the inverter manufacturer.

Danger to life from electric arc!

When exposed to light, solar modules produce direct current. If a closed circuit is opened, e.g. when the DC line is disconnected from the inverter under load, a fatal electric arc can occur.

- + Under no circumstances disconnect the solar generator from the inverter as long as it is connected to the mains.
- + Ensure flawless cable connections. Connect cables seamlessly and keep them free from dirt.

Electrical installation

The solar modules are designed for use in PV systems of application class A and can therefore be operated in systems with dangerous direct voltages (greater than 120 V DC according to EN 61730) and power ratings. PV modules of this application class may be used in systems with unlimited accessibility.

Solar Fabrik GmbH modules of the Mono S5, Mono S4, Mono S3 series, which are qualified within this application class according to EN 61730, meet the requirements of protection class II when installed in accordance with regulations.

Transport, intermediate storage and safe unpacking

The modules are sensitive technical components that require the greatest care when handling. Therefore, take particular care when transporting and storing them temporarily, and leave the modules in their packaging until they are ready for use. Always lift and carry the modules with both hands and do not use the connection box as a hand grip. Leave the cable ties on the plug connectors. During installation, remove the cable ties with side cutters or a suitable cutting tool. Take care not to damage the cable.

Do not drop the modules or place them roughly on hard ground or on the corners of the modules. Do not place objects on the modules. Do not stack modules on top of each other without protection. Avoid bending the modules. Do not step on the modules. Do not work on them with sharp objects and keep all electrical contacts clean and dry.

Avoid bending the modules. Do not step on the modules. Do not work on them with sharp objects and keep all electrical contacts clean and dry.

Note: We recommend keeping a complete system plan for each solar project, including the installation date, location and serial numbers of the components used. To do this, document all module serial numbers of the planned solar modules before installation.

If intermediate storage of the modules is necessary, a dry, ventilated room should be provided.

Clean, non-slip gloves must be worn during all transport and installation work to prevent injury from cuts on module edges. In addition, avoid soiling the solar glass with fingerprints, as they can damage the special coating of the glass.

It is essential to observe the warnings on the packaging and the enclosed unpacking instructions. You can find these on our website under Downloads. [[to the instruction](#)].

Solar module mounting instructions

Mono S5 / Mono S4 / Mono S3

3. Installation of the module

Ensuring safe installation

Secure yourself and other persons against falls; do not carry out installation work in strong winds and prevent objects from falling if possible. Carefully secure the working area to avoid danger or injury to persons.

It is essential to comply with the maximum permissible mechanical load in accordance with IEC 61730 and IEC 61215.

The load capacities specified in the installation instructions are based on tested load values. For solar modules in accordance with IEC 61730 and IEC 61215, a safety factor of 1.5 should be taken into account when calculating the maximum permissible design loads. The actual design loads of a project may vary depending on the construction method, location, climate, relevant standards and other influencing factors.

The supplier of the support system or substructure and/or a qualified specialist planner is responsible for determining these loads. Comply with the locally applicable building regulations or contact a civil engineer for detailed information.

When using fasteners, cable ties or similar connecting materials between the rear of the module and the cross profiles, ensure that damage to the module is avoided by sharp or uneven structures.

Ensuring that the modules are properly earthed

In accordance with the provisions of Solar Fabrik GmbH, it is not necessary to earth the module frames and rack for trouble-free operation. To avoid the risk of electric shock (e.g. from static charges) as far as possible, Solar Fabrik GmbH recommends having the installer carry out professional earthing.

If an external lightning protection device is available, a technical specialist must integrate the PV system in the lightning protection concept while observing country-specific standards and regulations

A qualified electrician must check the earthing connections between the modules. A qualified electrician must

also connect the main earthing.

An earthing method approved by Underwriters Laboratories (UL) is mandatory in the USA and Canada. For proper earthing, ensure optimum electrical conductivity. For this purpose, earthing holes are provided on the back of the module frame. These earthing holes are marked with a stamped earthing symbol.

To ensure proper grounding, optimal electrical conductivity must be guaranteed. For this purpose, grounding holes are provided on the back of the module frame. These grounding holes are marked with an embossed grounding symbol.

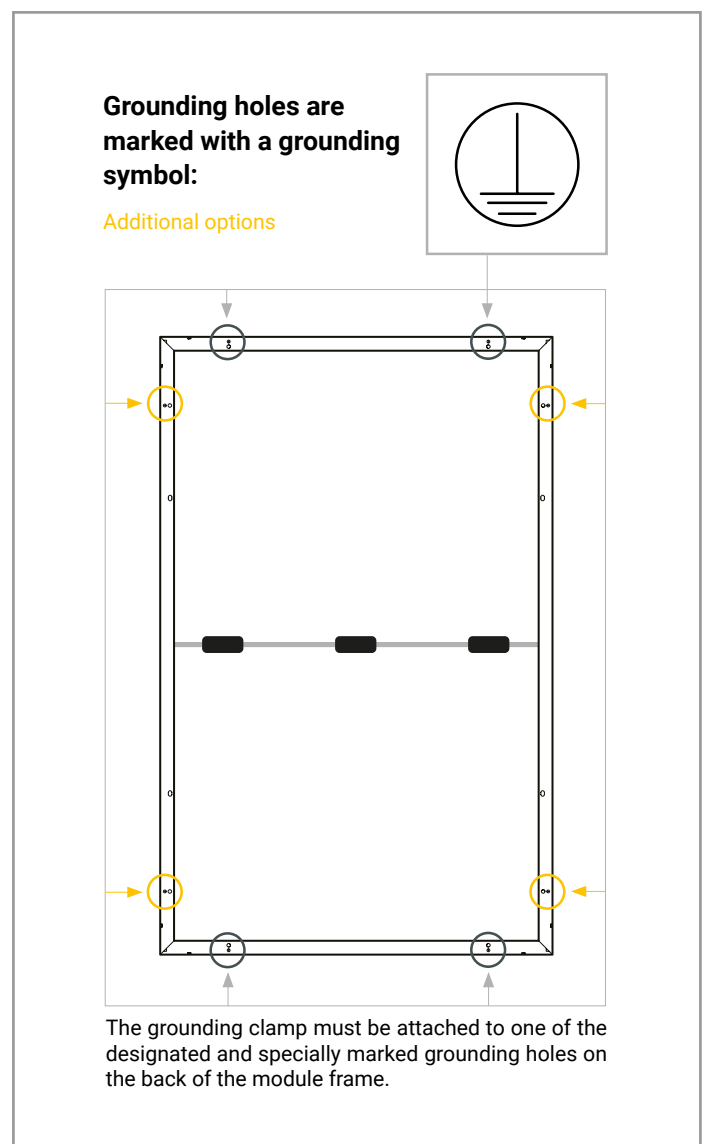

Solar module mounting instructions

Mono S5 / Mono S4 / Mono S3

Correct handling of AR glass modules

The nanoporous coating on the glass surfaces of the solar module reduces reflection losses. Compared to uncoated glass, this can result in up to 2% more power output when the angle of incidence deviates from the vertical. However, this also means that the module may experience temporary visible discolouration. This extremely thin structure can temporarily absorb airborne particles. Therefore, slight optical differences may also occur due to production tolerances, which are particularly visible in diffuse light. To maintain this effect and avoid optical impairments, we strongly recommend that you observe the following instructions:

- + Handle the modules with care due to the coated glass.
- + Handle the modules with care when unpacking and mounting. We recommend only touching the surfaces with clean gloves because the special reflective properties make light soiling easier to detect. Especially grease and oil are visible even in small quantities and can influence the transmission.
- + We advise against attaching stickers or labels to the coated surface. Depending on the material used, this can result in very fine residues that are difficult to remove.
- + In rare cases, there may be visible white residues of the coating fluid and colour variations in the edge area (≤ 5 mm). These are fully functional modules and there is no reduction in quality.
- + In the event of heavy soiling, we recommend cleaning the modules, as otherwise local hot spots may occur [more on this on [page 9](#)].
To do this, proceed as follows:
 - + Clean the modules when they have cooled down (e.g. during the morning hours).
 - + For moderate to strong residues, we recommend cleaning with lukewarm, de-mineralised water and clean, lint-free cotton cloths, microfibre cloths or paper towels.
 - + For particularly heavy and stubborn soiling, we recommend detergents containing surfactants.
 - + Avoid cleaning with strong acids, alkaline solutions, petrol-based cleaners, steam and hot cleaners, cleaners with silicone oils, fluorides or waxes, polishes, alkaline cleaners and cleaners with scouring agents and high-pressure cleaners.
- + This so-called anti-reflective coating is subject to manufacturing tolerances arising from the materials and processes used, which may result in colour variations in the appearance of the modules, within the tolerances customary in the industry. These differences may be particularly noticeable in diffuse light and do not constitute a material defect within the meaning of the statutory warranty; nor do they give rise to any claim for rectification, replacement or a reduction in price. It is expressly noted that the anti-reflective coating can enhance the performance of the PV modules and does not constitute a quality defect. Based on current experience, optical differences may even out over the course of the first few years of operation due to weather and environmental influences, without this giving rise to any claim under warranty or for replacement. The system can be operated without restriction, taking these visual characteristics into account. During commissioning, temporary visible discolouration may also occur, which likewise does not constitute a defect.

Note: If particular importance is attached to ensuring that the roof surface looks as uniform as possible, we strongly recommend that you consult our sales team or Solar Fabrik directly before purchasing and, in particular, before installing the PV modules. Working together, we can select a product at an early stage that is optimally tailored in terms of appearance, colour scheme and module characteristics.

Solar module mounting instructions

Mono S5 / Mono S4 / Mono S3

Technical explanation of the cell production process of a solar module

- + The cells we use in the production of our panels are classified as ‚A-Grade‘ cells without exception. However, the cell sorting process is undertaken both manually and mechanically. This can already lead to heterogeneous cell colours, which become visible through a black backing film.
- + The cells used are both 166mm x 83mm and 182mm x 91mm Mono Perc P-Type Halfcut cells or TOPCon N-Type Halfcut cells. These module cells were subjected to a coating thickness tolerance, this process can also result in differences in colour.
- + The cells were also treated with plasma-enhanced chemical vapour deposition (PECVD) during the production process. This separation process guarantees improvements in efficiency. However, it can also result in differences in colour within the blue colour family. Consequently, module cells may be light blue to grey colour.

Regardless of these processes, Solar Fabrik modules are re-tested by an independent testing laboratory. In this process, electroluminescence reveals the desired quality features, ensuring trouble-free operation.

Ensure comprehensive fire protection

The installation of rooftop systems may, under certain circumstances, affect the fire safety of a building. Improper installations, in particular, can pose a fire hazard. Since the module is classified as non-explosion-proof equipment, it must not be installed near easily flammable gases and vapors, such as near gas containers, paint spraying systems, or gas stations. The module must also not be installed next to open flames or flammable materials. It is important that the system always complies with local conditions, laws, and regulations.

Pay attention to an appropriate environment

The module is primarily designed for use in moderate climatic conditions. Ensure that it is not exposed to artificially concentrated sunlight at its installation site, nor submerged or continuously exposed to spray water.

In cases of exceptional exposure to salts or sulfur, there is a risk of corrosion.

Ensure the suitable installation situation

It is of utmost importance that the module meets the technical requirements of the overall system. Therefore, ensure that no harmful mechanical or electrical effects (e.g., overvoltage) are exerted on the module by other system components.

In a series connection, only modules with the same current rating should be used, and in a parallel connection, only modules with the same voltage should be employed. The modules must only be operated with the permissible system voltage; operation at a higher voltage is not intended.

Choose the correct mounting location

The module must not be installed as overhead glazing, such as on a facade. In addition to the module itself, the mounting system must also be able to withstand the expected load from the conditions at the installation site (snowfall, wind) without issue.

The underside of the module frame is equipped with openings that allow rainwater to drain. When installing, ensure that these openings are not obstructed in their function. For vertical installation, mounting with the junction box facing both upwards and downwards is allowed. Otherwise, only installation with the junction box facing upwards is permitted.

Secure yield through optimal orientation and tilt

Before installation, we recommend that you find out about the appropriate orientation and angle of inclination for the modules so that the system can achieve optimum yield performance. The mounting angle must always be greater than 5° to ensure sufficient self-cleaning of the system by rain. When the sun's rays hit the generator surface vertically, the conditions are ideal for power generation. To avoid performance losses in a series connection, please ensure that all modules are installed with the same orientation and inclination.

Solar module mounting instructions

Mono S5 / Mono S4 / Mono S3

Avoiding permanent shading of solar modules

To ensure reliable and efficient operation of your photovoltaic system, it must be exposed to sunlight without obstruction in all seasons. The modules must not be permanently shaded – either completely or partially. This applies to selective, uniform or uneven shading.

Permanent shading is defined in particular as repeated or prolonged shading of individual cells, rows of cells or specific sections of the module.

Possible consequences of permanent shading:

- + Loss of performance and reduced energy yield
- + Local overheating (so-called hot spots)
- + Shortened service life of the module
- + Thermal stress on the bypass diodes
- + Accelerated ageing of the encapsulation materials

Important:

Permanent shading can void the limited product and performance warranty.

Exception:

Shading is compensated for by suitable power electronic components such as module optimisers.

Dirt (e.g. from leaves, dust, plant growth or bird droppings) can also cause partial shading and thus impair module performance. Regular cleaning and maintenance of the modules is necessary to prevent shading caused by dirt [more on this on [page 17](#)].

This not only impairs the performance of the affected module, but can also lead to local overheating (hot spots).

Excluding hotspots

Hot spots occur when individual shaded or dirty cells in a module become resistors and excess energy is converted into heat.

Possible consequences are:

- + Thermal damage to the cells or the module surface
- + Stress on the bypass diodes
- + Shortened module service life
- + Loss of warranty claims due to inadequate maintenance

Recommendation for prevention:

- + Carry out regular visual inspections and cleaning, especially:
 - + after pollen dispersal
 - + after prolonged dry periods
 - + in dirty environments (e.g. agriculture, industry, traffic routes)
- + Ensure sufficient slope and good drainage to prevent deposits and standing water.
- + Use soft water and suitable tools for cleaning, and do not use aggressive cleaning agents [More on this [page 17](#)].

Note: A clean module surface is crucial for the reliable operation and long-term performance of your PV system.

Install the module in a shading-free location

Therefore, you should always pay attention to the environmental conditions when installing a solar power system.

Do not install PV modules directly behind objects such as trees, antennas, chimneys or similar structures that can cause permanent shading. Temporary or partial shading should also be avoided or compensated for by module optimisers.

Solar module mounting instructions

Mono S5 / Mono S4 / Mono S3

Ensuring sufficient rear ventilation

A gap between the rear of the module and the roof covering allows air to circulate and heat to dissipate effectively. This contributes to a longer service life for the module.

We recommend a minimum gap of approx. 10 cm. Please note: The actual gap required may vary and depends on:

- + the roof construction (e.g. roof insulation),
- + the air circulation at the installation site,
- + the orientation and pitch of the roof, and
- + the climatic conditions at the location.

In some cases, a larger distance may be necessary to ensure sufficient cooling.

The exact design should be determined in consultation with the manufacturer of the mounting system and, if necessary, a qualified specialist planner or energy consultant.

Secure mounting

In order to mount the modules as intended, they must each be securely fastened by at least four points. Framed PV modules may be clamped on the short and on the long sides.

NOTE: Ensure that the maximum mechanical load capacity of the modules is observed, taking into account the wind and snow load zones as well as the terrain category and building height.

NOTE: Due to temperature fluctuations, the length of the mounting rails may change. The maximum length of the substructure rail can be found in the manufacturer's installation instructions. Rails that are too short must be levelled out with a length expander. Modules must not be mounted directly on the expander.

The module frames are also subject to thermal expansion and cold contraction. A distance of 10 mm between neighbouring modules must therefore be maintained during installation.

Instructions for installation

The modules can be connected to the substructure in various ways: either by clamping the modules from the front (see example 1) or by screwing the modules into the mounting

holes provided from behind (see example 2).

Use a torque wrench during installation. In the examples shown, the tightening torque to be applied is between 16-20 Nm. Please note that 20 Nm must not be exceeded. M8 screws made of V2A must be used. Only use the existing drill holes for installation. The drilling of further holes would lead to a loss of warranty.

Load capacities

Depending on the type of installation, the solar modules are capable of withstanding the corresponding load. As a general rule, care should be taken to ensure that the solar modules are not exposed to unnecessary stress [More on [page 6](#)].

When using the clamp-on mounting method

When using the clamp mounting method (see example 1), the mounting points in the specified clamping areas must be taken into account. A graphic representation of the clamping areas can be found on page 10. Please note that failure to comply with these instructions will void any warranty claims.

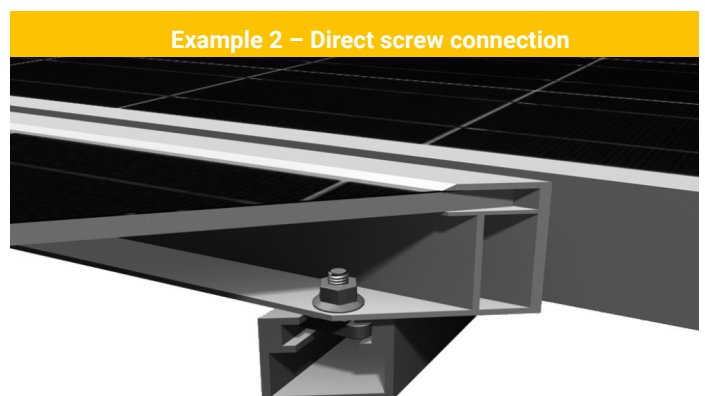
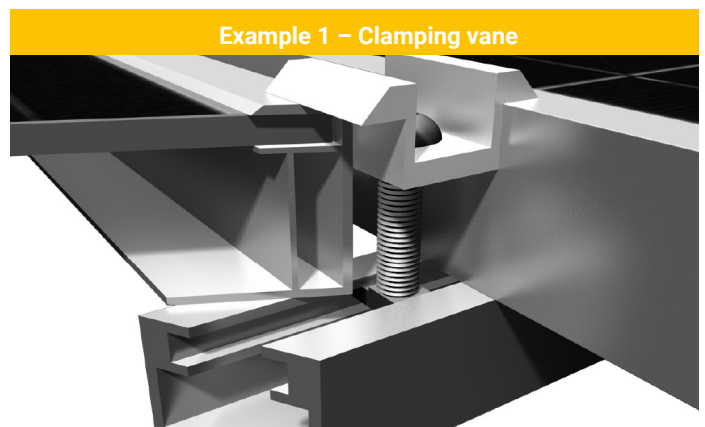

Mounting-Variants | standard modules | Test load 2400 Pa / -1600 Pa

Module frame selective stored

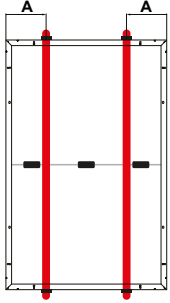

Solar module	Mounting (clamped 4x)
Mono S3 [HC]	A = 200-300 mm
Mono S5 [HC]	A = 200-300 mm
Mono S4 [HC]	A = 250-350 mm
Mono S4 [HC BC]	A = 250-350 mm

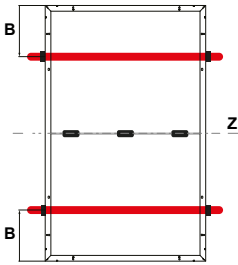

Solar module	Mounting (clamped 4x)
Mono S3 [HC]	B = 0-300 mm
Mono S5 [HC]	B = 0-300 mm
Mono S4 [HC]	B = 0-300 mm
Mono S4 [HC BC]	B = 0-300 mm

Module frame stored flat/aerodynamically

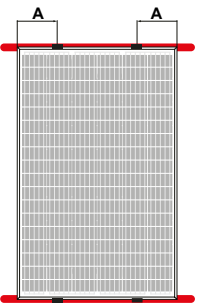

Solar module	Mounting (clamped 4x)
Mono S3 [HC]	A = 200-300 mm
Mono S5 [HC]	A = 200-300 mm
Mono S4 [HC]	A = 250-350 mm
Mono S4 [HC BC]	A = 250-350 mm

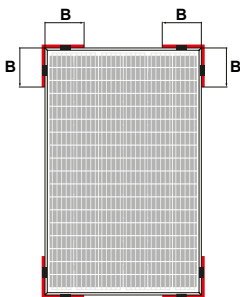

Solar module	Mounting (clamped 4x)
Mono S3 [HC]	B = 0-250 mm
Mono S5 [HC]	B = 0-250 mm
Mono S4 [HC]	B = 0-250 mm
Mono S4 [HC BC]	B = 0-250 mm

Z= vertically centred

We can provide recommendations for screwing our modules together on request.

Mounting-Variants | standard modules | Load capacity 3600 Pa / -2400 Pa

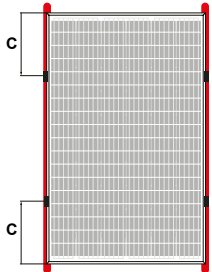
Module frame stored flat		
	Solar module	Mounting (clamped 4x)
	Mono S3 [HC]	C = 300-450 mm
	Mono S5 [HC]	C = 300-450 mm
	Mono S4 [HC]	C = 300-450 mm
	Mono S4 [HC BC]	C = 300-450 mm

Mounting-Variants | standard modules | Load capacity 5400 Pa / -3600 Pa

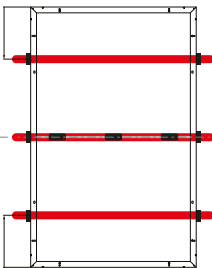
Module frame selective stored		
	Solar module	Mounting (clamped 6x)
	Mono S3 [HC]	B = 250-350 mm
	Mono S5 [HC]	B = 250-350 mm
	Mono S4 [HC]	B = 250-350 mm
	Mono S4 [HC BC]	B = 250-350 mm

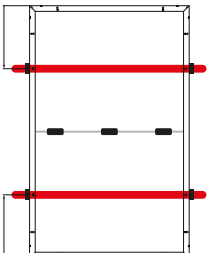
	Solar module	Mounting (clamped 4x)
	Mono S3 [HC]	B = 300-450 mm
	Mono S5 [HC]	B = 300-450 mm
	Mono S4 [HC]	B = 300-450 mm
	Mono S4 [HC BC]	B = 300-450 mm

Z= vertically centred

We can provide recommendations for screwing our modules together on request.

Mounting-Variants | standard modules | Load capacity 8100 Pa / -5400 Pa

Module frame selective stored

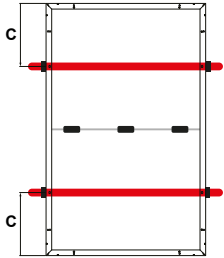

Solar module	Mounting (clamped 4x)
Mono S5 [HC]	C = 290–450 mm

Z= vertically centred

We can provide recommendations for screwing our modules together on request.

Mounting-Variants | project modules | Load capacity 1600 Pa / -800 Pa

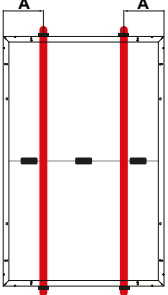
Module frame selective stored		
	Solar module	Mounting (clamped 4x)
	Mono S4 [HC]	A = 55-240 mm

Mounting-Variants | project modules | Load capacity 1600 Pa / -1200 Pa

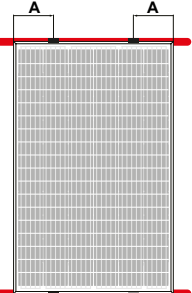
Module frame stored flat/aerodynamically		
	Solar module	Mounting (clamped 4x)
	Mono S4 [HC]	A = 200-350 mm

Z= vertically centred

We can provide recommendations for screwing our modules together on request.

Mounting-Variants | project modules | Load capacity 2400 Pa / -1600 Pa

Module frame selective stored

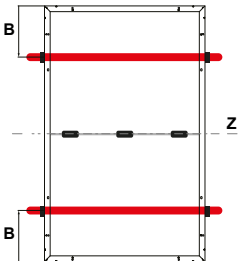
	Solar module	Mounting (clamped 4x)
	Mono S4 [HC]	B = 300-520 mm

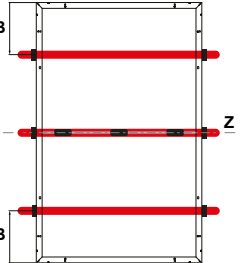
	Solar module	Mounting (clamped 6x)
	Mono S4 [HC]	On request

Module frame selective stored

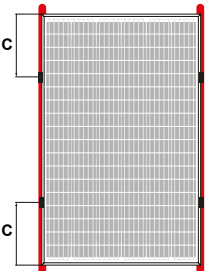
	Solar module	Mounting (clamped 4x)
	Mono S4 [HC]	C = 450-600 mm

Z= vertically centred

We can provide recommendations for screwing our modules together on request.

Proper cabling

Under no circumstances open the junction box. The modules are already equipped ex works with the necessary cables and connectors.

Ensure correct wiring

The integrated connecting cables are UV-resistant. The connecting cables have a conductor cross-section of 4 mm². For connection, the connecting cables have pre-assembled connectors that are protected against reverse polarity. Ensure that the total area of all conductor loops is kept as small as possible to reduce voltages caused by indirect lightning strikes. It is essential to subject the wiring to a thorough final check before the generator is put into operation. If the measured open-circuit voltage deviates from the specification, there is a connection error. Also make sure the polarity is correct.

Insert the plug connectors correctly. Connectors may only be inserted in a dry condition. Also make sure that gap-free connection is possible. In addition, the requirements of the inverters that are used must be observed.

The modules are connected in parallel, appropriate over-current protection must be used. Fuses for DC voltage must be used for this purpose, which prevent a reverse current greater than 15 A.

Also observe the connection conditions and the design guidelines of the inverter manufacturers.

Check the plug-in connection of the supplied modules before installation and if the completed strings are working correctly after completion of each string. This is performed by means of a voltage test. Explicit attention must be paid here to the snap-in between the plastic cable sheath and the aluminium cable sheath. The snap-in should be audible. If the string and/or the plug-in connection does not appear to work correctly, contact Solar Fabrik GmbH immediately.

Using suitable materials only

The system may only be wired with special solar cables in accordance with DIN EN 50618 class 5 and suitable plugs.

It is of utmost importance that all materials used are in perfect electrical and mechanical condition. Only use single-core cables and select the appropriate conductor cross-section to minimise the voltage drop.

Only use suitable cables with a minimum cross section of 4 mm² for the further connection of the modules. For longer distances, the cable cross section must be adjusted accordingly.

For cable laying, also follow the specified requirements in accordance with DIN VDE 0298-3.

Solar module mounting instructions

Mono S5 / Mono S4 / Mono S3

Protecting the cables from damaging environmental influences

Only use UV-resistant cable ties to fix the cables to the mounting system. Protect exposed cables from possible damage, e.g. by laying them in plastic pipes. Avoid direct sunlight.

Under normal conditions, a PV module can deliver a higher current and/or voltage than specified in the standardised test conditions under expected conditions. To determine the rated voltage values of components, rated current values of conductors, sizes of fuses and dimensioning of controllers connected to the output of PV modules.

The values of I_{sc} and U_{oc} edges. Furthermore, avoid soiling indicated on the module should therefore be multiplied by a factor of 1.25.

Ensuring the plug connectors are correctly installed

All connectors sold by Solar Fabrik GmbH can be combined with the Stäubli EVO 2.

In order to ensure that connectors are used correctly, it is permitted to replace the module connector supplied by Solar Fabrik without losing the product warranty (e.g. with the Stäubli EVO 2). Installation must be carried out by qualified personnel in accordance with the technical documentation supplied with the connector. Please contact your Solar Fabrik GmbH sales representative for information on compatibility.

The mounting of the connector on the module must be carried out according to the mounting instructions enclosed with the connector. The complete reassembly of the plug connector may only be carried out at ground level. It is also important to ensure that the module is not connected to the generator field during operation.

The photoactive front side of the module should be covered as far as possible or face the ground during all work steps to keep the voltage low. If all installation instructions are observed and the installation is carried out by a technical specialist, the product guarantee of the modules remains in full force. Rainfall usually cleans the modules automatically.

Maintenance and cleaning

If the modules are sufficiently inclined (greater than 15°), separate cleaning is generally not necessary. If the modules are very dirty, we recommend cleaning them with plenty of water, but without detergent.

Clean, non-slip gloves must be worn during all transport and installation work to avoid cuts from the edges of the modules. In addition, fingerprints must be avoided on the solar glass, as these can damage the special coating on the glass.

In the case of heavy soiling, we recommend cleaning with plenty of low-lime water. The pH value of the water should be between 6.0 and 7.5. Please note that no nozzle attachment should be used and only appropriate water pressure and temperature should be applied. The use of cleaning agents and abrasive cleaning equipment will damage the special anti-reflective coating and void the product and performance warranty. Under no circumstances should contaminants be scraped or rubbed off when dry. Damage to the highly efficient anti-reflective surface can lead to optical changes in the module surface and loss of performance.

The use of automatic cleaning machines for solar systems is at your own risk and is not approved by Solar Fabrik GmbH.

- + secure fastening and freedom from corrosion of all fastenings.
- + secure connection, cleanliness, integrity and freedom from corrosion of all cable connections.
- + Contact resistance of the equipotential bonding.

Solar module mounting instructions

Mono S5 / Mono S4 / Mono S3

Instructions for disassembly -> Shut down!

- + Disconnect the inverter(s) on the AC side from the mains supply so that the photovoltaic system is without load.
- + Disconnect the photovoltaic system from the inverter at the DC-side disconnection point.
- + Make sure that voltage is no longer applied to the system.
- + The photovoltaic system can now be disassembled. Please observe the safety instructions.

Disposal of the modules

Disposal and recycling of solar modules are regulated by the Electrical and Electronic Equipment Act (ElektroG), which transposes the WEEE Directive into German law. Please also observe country-specific regulations. It is possible that notification is required in the respective country.

Note on liability and status of the instructions

If the instructions contained in this user information have been deviated from, Solar Fabrik GmbH accepts no responsibility for the usability and functionality of the modules. Please note that failure to comply with these instructions will void any warranty claims.

Since compliance with the safety instructions mentioned above and the conditions and methods of installation, operation, use and maintenance of the modules cannot be controlled or monitored by Solar Fabrik GmbH, Solar Fabrik GmbH also accepts no liability for damage resulting from improper use, faulty installation, operation, use or maintenance.



The information regarding packaging and transportation
valid at the time of the document's release applies.

Subject to changes.