

User Manual

Power Conversion System (PCS)

SC100CX/SC110CX/SC125CX



Contents

1	About This Manual	1
1.1	Validity.....	1
1.2	Target Group.....	1
1.3	Symbol Explanations	1
1.4	How to Use This Manual	2
2	Safety Instructions	3
2.1	Intended Usage.....	3
2.2	Safety Instructions	4
2.2.1	Important Safety Instructions.....	4
2.2.2	Manual Storage	4
2.2.3	Storage Battery Protection	5
2.2.4	Ground Fault Protection.....	5
2.2.5	Live Line Measurement	5
2.2.6	Measuring Instrument.....	6
2.2.7	Voltage-free Operations.....	6
2.2.8	Arc Protection	6
2.2.9	ESD Protection	7
2.2.10	Sand and Moisture Protection	7
2.2.11	Markings on the Product	7
2.2.12	Safety Warning Signs	7
2.2.13	Daily Operation and Maintenance.....	8
2.2.14	Disposal of Waste	8
2.2.15	Manual Description.....	9
3	Product Description	10
3.1	Product Introduction.....	10
3.2	Product Description	10
3.2.1	Model Description	10
3.2.2	Product Exterior	11
3.2.3	Mechanical Dimensions.....	13
3.3	Technical Description.....	13
3.3.1	Principle Description.....	13

3.3.2	Functions Description	15
3.3.3	Schema description.....	15
4	Installation Flow	16
5	Unpacking and Storage	18
5.1	Unpacking and Inspection	18
5.2	Identifying PCS	18
5.3	Storage of PCS	20
6	Installation	22
6.1	Inspection Before Installation.....	22
6.1.1	Deliverables Inspection	22
6.1.2	Check the Device	22
6.2	Transport.....	23
6.3	Installation Tools.....	23
6.4	Installation Position.....	24
6.5	Installation Environment Requirements	25
6.5.1	Installation Site Requirement	25
6.5.2	PCS Cooling Requirements	26
6.6	Installation Operation	27
7	Electrical Connection	30
7.1	Safety Instructions	30
7.1.1	General Rules.....	30
7.1.2	Five Safety Rules.....	32
7.2	Terminal Description	32
7.3	Battery Connection	33
7.3.1	Precautions	33
7.3.2	Cable Connection	34
7.4	Steps for AC Wiring	38
7.4.1	Safety Precautions	38
7.4.2	Wiring Steps	38
7.5	Communication Connection	40
7.6	Grounding.....	40
8	Commissioning	42
8.1	Safety Instructions	42
8.2	Commissioning Requirements	43
8.3	Checking Before Commissioning	43
8.3.1	Checking Cable Connection.....	43

8.3.2 Check PCS.....	44
8.3.3 Checking the Batteries	44
8.3.4 Checking Grid Voltage.....	44
8.4 Preparation Before Booting	45
8.5 Commissioning Steps	45
9 Disconnecting, Dismantling and Disposing the PCS	47
9.1 Shutdown	47
9.2 Dismantling the PCS.....	47
9.3 Disposing the PCS	48
10 iSolarCloud APP	49
10.1 Brief Introduction	49
10.2 Download and Install.....	49
10.3 Login	50
10.3.1 Requirements	50
10.3.2 Login Steps	50
10.4 Introduction to Cybersecurity Mode	51
10.5 Cybersecurity Mode Switch	53
10.6 Test and Adjustment (iSolarCloud App)	54
10.7 Firmware Update.....	55
11 Troubleshooting and Maintenance	57
11.1 Troubleshooting.....	57
11.2 Maintenance.....	65
11.2.1 Routine Maintenance.....	65
11.2.2 Maintenance instructions	65
12 Appendix	67
12.1 Technical Data.....	67
12.2 Tightening Torques	68
12.3 Quality Assurance	68
12.4 Contact Information	69

1 About This Manual

1.1 Validity

This manual applies to the following models of Turnkey Station. :

- SC100CX
- SC110CX
- SC125CX

The Turnkey Station hereinafter it will be referred to as "PCS" unless otherwise specified.

PCS: Power Conversion System.

1.2 Target Group

This manual is intended for technical personnel responsible for the transportation, installation, commissioning, and other related operations of the DC/AC power converter unit. Only qualified personnel are permitted to carry out installation, maintenance, and troubleshooting tasks. Unauthorized individuals must keep a safe distance from the DC/AC power converter unit to avoid potential hazards. Qualified personnel must be:

- Equipped with sufficient knowledge of electricity, electrical wiring, and mechanical systems, and familiar with electrical and mechanical schematic diagrams.
- Familiar with the construction and working principle of the energy storage system.
- Familiar with the construction and working principle of the DC/AC power converter unit's upstream and downstream equipment.
- Trained specifically for electrical equipment installation and commissioning.
- Capable of handling hazardous and emergency situations that may arise during installation and commissioning.
- Familiar with national or regional standards and regulations.
- Familiar with the contents of this manual.

1.3 Symbol Explanations

This manual contains important safety and operational instructions that must be accurately understood and respected during the installation and maintenance of the equipment.

To ensure the optimum use of this manual, note the following explanations of the symbols used.

⚠ DANGER

DANGER indicates a hazard with a high level of risk which, if not avoided, will result in death or serious injury.

⚠ WARNING

WARNING indicates a hazard with a medium level of risk which, if not avoided, could result in death or serious injury.

⚠ CAUTION

CAUTION indicates a hazard with a low level of risk which, if not avoided, could result in minor or moderate injury.

NOTICE

NOTICE indicates a situation which, if not avoided, could result in equipment or property damage.



NOTE indicates additional information, emphasized contents or tips to help you solve problems or save time.

1.4 How to Use This Manual

Please read through this manual carefully before using the product and keep it properly in an easy-to-reach place, to avoid equipment damage or safety incidents caused by operation not in line with the safety instructions specified in the manual.

A large number of pictures are provided to help users better understand and use this manual. These pictures are used for illustration only and may not be an exact representation of the real product.

The products and product manuals will be constantly improved and updated. If the manual received is slightly inconsistent with the product, it may be a result of a product update, and the actual product shall prevail. For any questions, please contact SUNGROW Customer Service.

2 Safety Instructions

2.1 Intended Usage

SC100_110_125CX is a three-phase grid-connected PCS applicable to energy storage systems.

The charging and discharging system with PCS is shown below:

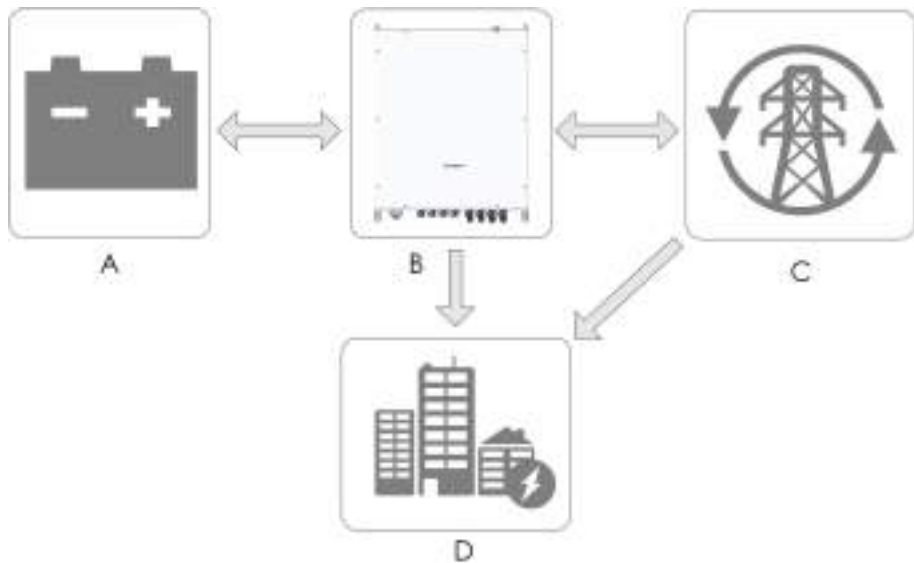

No.	Device
A	Energy storage batteries
B	PCS for energy storage system
C	Utility grid (Applicable grid: TN, TT, IT)
D	Loads

⚠ WARNING

- Installation described in this section must be strictly observed. Any other or additional installation other than the described installation is not permitted.
- Installation and connections other than the contents described in this section may lead to device damages and void warranty claims.

2.2 Safety Instructions

2.2.1 Important Safety Instructions

This section provides safety instructions for DC/AC power converter unit operation. Before operation, carefully read the safety instructions in this section and follow all warnings, instructions, and cautions provided here and throughout the manual.

DANGER

Electric shock hazard!

Danger to life from burns or electric shocks caused by contact with live components of the DC/AC power converter unit.

- Do not touch the live components of the DC/AC power converter unit or the utility grid.
- Observe all the relevant safety regulations.

DANGER

Electric shock hazards inside the DC/AC power converter unit!

- Observe at all times the warning labels on the product.
- Observe all safety instructions in this manual and other related document.

DANGER

Electric shock or fire due to device damage or system fault!

- Visual check if there is device damage or other potential dangers before operation.
- Check if other external devices or circuit connections are safe.
- Operate the device only when it is confirmed to be safe.

WARNING

Strictly follow the procedures in this manual to power the device after maintenance or troubleshooting.

2.2.2 Manual Storage

Manuals are an essential part of the product. It contains critical information regarding transport, installation, maintenance, and troubleshooting. All instructions, especially those related to safety, must be strictly followed. Be sure to read the entire manual carefully before performing any operation on the DC/AC power converter unit.

- Always transport, install, maintain, and service the DC/AC power converter unit in strict accordance with the instructions in this manual. Failure to do so may result in equipment damage, personal injury, or property damage.
- This manual and all related documents must remain accessible to all relevant personnel at all times.

2.2.3 Storage Battery Protection

High Voltages exist between positive and negative polarities of the storage batteries. Electrical shock or life risk may occur by accidental touch.

DANGER

High voltages exist between the positive and negative polarity of the storage batteries!

- Ensure the PCS and storage batteries are completely disconnected during device maintenance.
- Place warning labels in the disconnection place to avoid accidental reconnection.

WARNING

To replug the battery after the battery output side switch or line is disconnected, you must ensure that:

- The PCS is in a shutdown state for at least 15 minutes.
- The inside of the machine is already in the safe voltage range.

2.2.4 Ground Fault Protection

DANGER

If a ground fault occurs in the DC/AC power converter unit, components that are normally voltage-free may carry lethal voltage. Accidental contact may result in serious injury or damage. Before performing any installation or operation, ensure that no ground fault exists in the system and take appropriate protective measures.

2.2.5 Live Line Measurement

DANGER

High voltages are present inside the device. Death resulting from burns and electric shock may be caused upon touching the live components of the DC/AC power converter unit. During live line measurement,

- Use suitable protective equipment, for example, dielectric gloves, and ensure you are accompanied by other personnel.

2.2.6 Measuring Instrument

Instrument for measurement of the electrical parameters must meet the requirements listed below:

WARNING

- **Instrument for measurement of the electrical parameters should be high-quality instrument with sufficient measuring range.**
- **Make sure the connection and use of the instrument are correct to avoid arc and other dangers.**
- **Use suitable protective equipment including insulated gloves if live line measurement is required.**

2.2.7 Voltage-free Operations

Perform operations on the DC/AC power converter unit only when all its internal devices are completely voltage-free.

- Avoid any accidental re-connections.
- Verify that no voltage or current is present with appropriate measuring instrument.
- Make necessary ground connections.
- Cover possible live parts to avoid accidental contact.
- Ensure a clear escape route.
- Wait at least 5 minutes after the DC/AC power converter unit shuts down to ensure it is completely voltage-free.

2.2.8 Arc Protection

DANGER

To avoid personal injury and device damage, the DC/AC power converter unit must be operated strictly in accordance with this manual. Improper handling may result in arc hazards and pose additional risks such as fire or explosion. SUNGROW assumes no responsibility for incidents such as arcing, fire, or explosion caused by failure to follow the instructions in the product manual or on the device labels.

Improper operations may cause arcing, fire, explosion, or other hazards inside the device. In the event of an accident, response must always be carried out by qualified personnel. Improper handling during an accident may lead to more extensive failures or additional accidents. Improper operations include:

- Connect or remove the fuse of the DC/AC power converter unit when it is energized.
- Touch the end of a potentially live cable that is not insulated.
- Touch the wiring bars, terminals, or other parts inside the device that may be energized.

- The power cable connection is loose.
- Parts such as screws are accidentally dropped into the power module.
- Incorrect operation by untrained and unqualified operators, etc.

Before operating the device, assess the operating area for potential arc hazards. If there is a risk of arcing:

- Operators must have received relevant safety training in advance.
- Assess the areas where electric shock may occur.
- Operators must wear compliant protective clothing when working in areas where electric shock may occur.

2.2.9 ESD Protection

⚠ CAUTION

Devices may be damaged irreversibly by ESD (Electrostatic Discharge).

- **Avoid unnecessary touching of the PCB (Printed Circuit Board).**
- **Observe all the ESD-related safety instructions. Wear proper PPE (Personal Protective Equipment), like wrist strap.**

2.2.10 Sand and Moisture Protection

Do not open the DC/AC power converter unit's door during sandy weather, thunderstorms, strong winds, hail, or when the ambient humidity exceeds 95%.

2.2.11 Markings on the Product

The markings on the DC/AC power converter unit provide important information about the safe operation of the unit and its internal devices. Do not remove or damage the markings.

NOTICE

Do not damage or tear the markings.

- **All markings on the product must be clearly visible.**
- **Replace the markings once they are damaged or unclear.**

2.2.12 Safety Warning Signs

Observe the following instructions during installation, maintenance, or troubleshooting of the DC/AC power converter unit:

- Place highly visible warning signs near the upstream and downstream switches of the DC/AC power converter unit to prevent accidental switching-on.
- Set up temporary warning signs or fences around the operation area.

- Remove the door keys and store them properly after maintenance or troubleshooting work is finished.

2.2.13 Daily Operation and Maintenance

During daily operation, ensure that the doors of the PCS and its internal components are closed and locked, and that the keys are removed and handed over to the designated personnel for safekeeping. This avoids accidents caused by unauthorized access and prevents internal devices from rain or damage caused by animals.

Additionally, perform regular inspection and maintenance on the PCS and its internal devices to ensure their long-term reliable operation.

WARNING

When working on the equipment that carries voltage, take protective insulation measures, and ensure at least two staff are present on-site at the same time. The PCS is usually deployed in an energy storage plant situated in a field environment away from urban areas. Please set up field rescue facilities as needed to meet emergencies.

During daily operation and maintenance, pay attention to the following at all times:

- Each electrical device in the converter, such as the PCS unit, is labeled with a nameplate. The nameplate contains important parameter information about the equipment, which should be protected when performing all operations on the PCS.
- Some devices in the PCS (mainly referring to the PCS unit) may have heat-generating devices, which will still have high temperatures when the equipment stops working. When operating such devices, it is recommended to wear anti-scald gloves or other protective equipment.
- The PCS unit and cooling fan in the PCS may produce some noise during operation, and the noise will be even greater when some equipment fails. It is recommended to wear noise-blocking earplugs when entering the PCS.
- The PCS and the cooling fan in the PCS unit can only be maintained when the fan stops rotating.
- If necessary, be equipped with appropriate protective equipment, such as goggles, insulated gloves, insulated shoes, etc., and take all necessary auxiliary measures to ensure the safety of personnel and equipment.

2.2.14 Disposal of Waste

When the DC/AC power converter unit or internal devices reach the end of their life, they cannot be disposed of together with household wastes. Some components inside can be recycled and some components can cause environment pollution.

Contact the local authorized collection point.

2.2.15 Manual Description



For user's convenience, there are a large number of pictures in this manual. These pictures are indicative only. For details about the device, refer to the actual product you receive.



Keep this manual at a convenience place near the device for future reference during installation, operation, maintenance and troubleshooting of the device.



All the descriptions in this manual are based on the standard MV power converter, and the actual product you receive may differ. If necessary, specify your requirements when placing the order.

This manual may not cover all possible situations. Should a specific problem occur that is not explained in this manual, contact SUNGROW.

3 Product Description

3.1 Product Introduction

Electric power system consists of the following six parts: development, generation, transmission, distribution, consumption and storage. Among which, the energy storage system is important to realize the following functions: demand side energy management, substation grid support, load balance, renewable energy application etc.

SC-series PCS are dedicated to charging/discharging the storage battery and providing intermediate link between the grid and the storage battery in different occasions (grid-connected system, islanded system or hybrid system).

Smart grid system with PCS for energy storage system is shown in following figure.

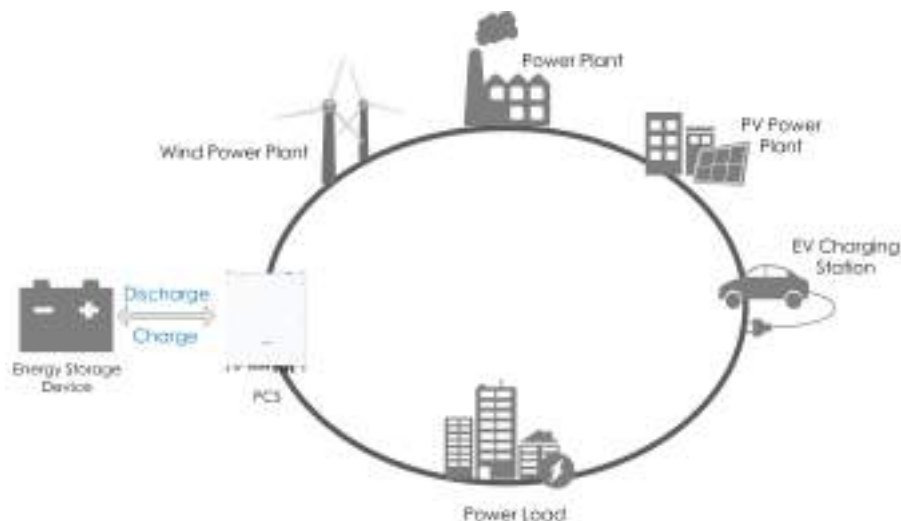

figure 3-1 Smart grid and energy storage system

3.2 Product Description

3.2.1 Model Description

The model description is as follows (take SC110CX as example):



3.2.2 Product Exterior

The exterior of the product is shown in the figure below.

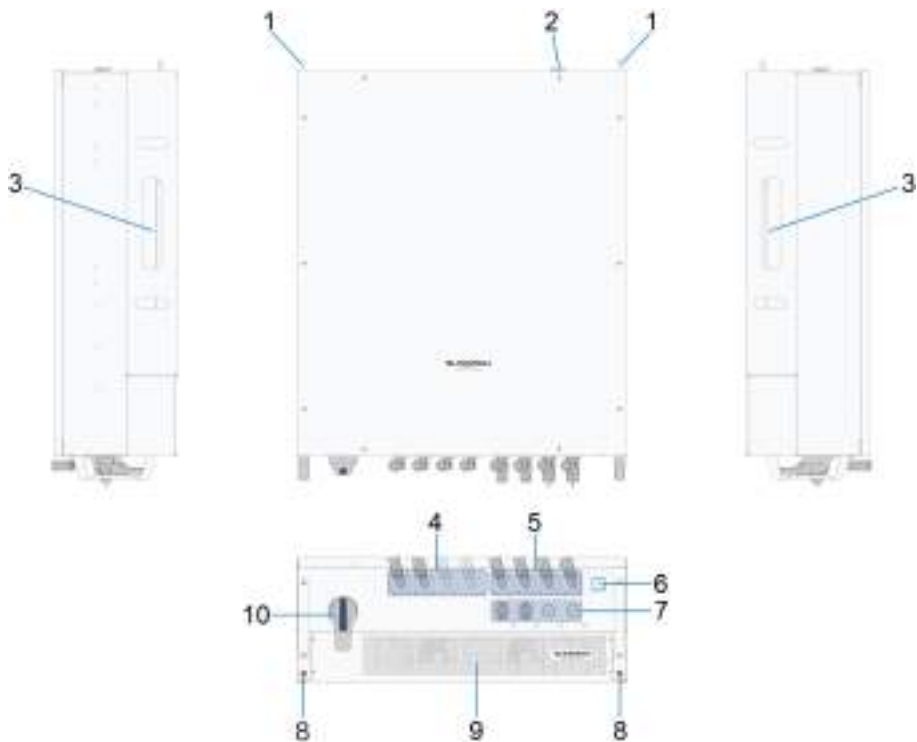

figure 3-2 Product Exterior

The figure shown here is for reference only. The actual product you have received may differ.

No.	Item	Description
1	Locating pin	Used to restrict the free movement of the PCS.
2	Vent valve	Resistant to dust and water; air permeable.
3	Rail	Used for transport, installation, and removal of the device.
4	DC input terminal	DC wiring area.
5	AC output terminal	AC wiring area.
6	LED Indicators	To indicate the device's current working status.
7	Communication port	Used for communication wiring.
8	*Secondary grounding terminal	Terminal used for secondary protective grounding as specified by EN50178.
9	Air inlet plate	The fan is located on the back of the cover plate, used for forced cooling.
10	DC switch	Used to safely disconnect the device from the battery.

⚠ WARNING





*** During product use, avoid DC positive-/negative-to-ground short circuits, and short circuits between positive and negative. Otherwise, it may lead to serious damages to the PCS!**

In case a short circuit fault has occurred, the whole PCS should be replaced!

LED Indicator Panel

The LED indicator panel serves as an interface for human-machine interaction and can indicate the current working status of the PCS.

table 3-1 LED Indicator Status Description

Indica- tor	Status	Description
	Steady on	The device is working.
	Blink fast (Interval: 0.2s)	The device is connected to bluetooth, with data communication in process.
		No fault is detected.
	Blink slow (fading) (Interval: 2s)	The device is powered on, and is in the emergency stop, standby, or startup state.
	Steady on	A fault has occurred (The device cannot connect to the grid).
	Blinking	The device is connected to bluetooth, with data communication in process.
		A device fault has occurred.
	Off	AC and DC sides are both disconnected from power.
Off		

3.2.3 Mechanical Dimensions

Dimensions



The figure is only an example, the specific subject to the actual.

3.3 Technical Description

3.3.1 Principle Description

Inversion circuit converts DC power into AC power, which will be fed into the utility grid via four core terminals. The PCS needs to be equipped with a protective fuse, isolation device or circuit breaker outside the AC and DC side to meet the equipment protection and operational safety.

The PCS provides Ethernet interface communication, and the schematic diagram of the main circuit is as follows.

figure 3-6 Schematic diagram of the main circuit (SC125CX–0.25C)

3.3.2 Functions Description

PCS functions can be grouped as the following:

- Conversion function

PCS converts the direct current power into alternating current power, which conforms to the grid requirement of its installation country.

- Data storage and display

The converter stores important data such as operating information and fault records, and displays them on the APP.

- Parameters configuration

PCS is available in a variety of parameter configurations for optimal functionality.

- Communication interface

Includes a standard RS485 communication interface for connecting other monitoring devices to the energy storage system.

- Protection functions

- Reverse polarity protection
- Overvoltage protection
- Grid monitoring / Ground fault monitoring
- Insulation monitoring
- Overheat protection

3.3.3 Schema description

PCS operation mode includes the grid mode and VSG mode.

Grid mode:

In grid mode, PCS can charge and discharge.

- Charging: constant voltage charging, constant AC power charging, etc.
- Discharge: Voltage limited discharge, constant AC power discharge, etc.

VSG mode :

This mode can be set via the LC . In VSG mode, PCS can simulate a synchronous generator and support on-grid or off-grid operation.

4 Installation Flow

The following figure shows the installation flow of PCS. Please follow these procedures when installing the PCS.

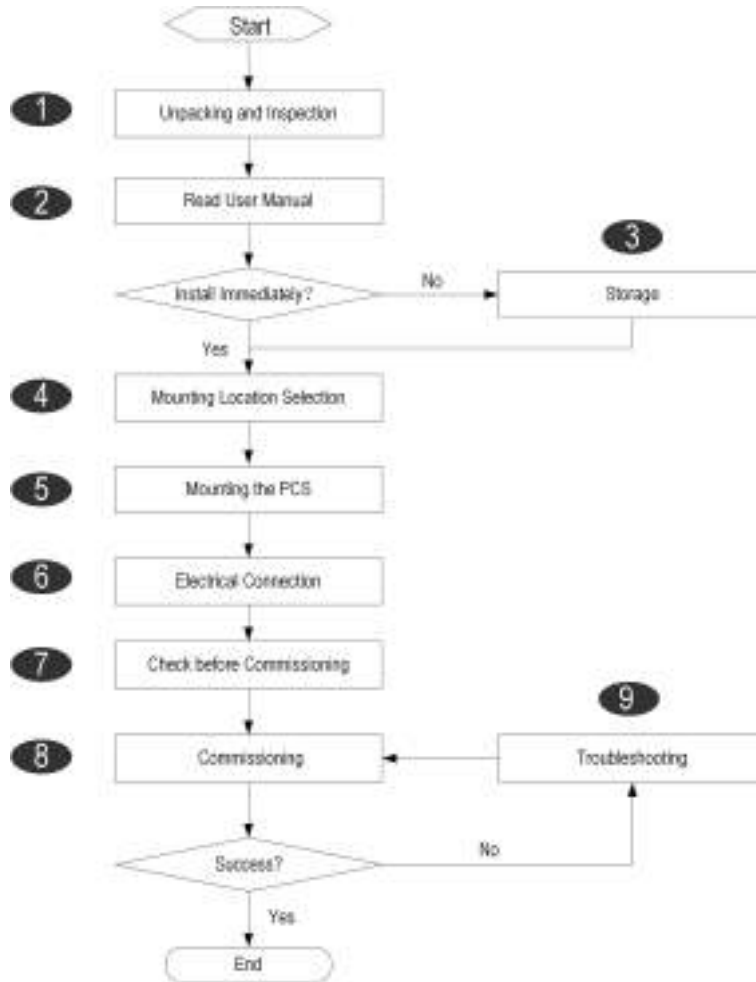

figure 4-1 Installation flowchart

table 4-1 Instructions for the installation process

No.	Description	Chapter References
1	Unpacking and inspection	Refer to "5.1 Unpacking and Inspection"
2	Read this manual, especially the "Safety Instructions" section	Refer to "2 Safety Instructions"
3	If it is not installed immediately, the PCS unit should be well stored	Refer to "5.3 Storage of PCS"

No.	Description	Chapter References
4	Choose the best place to install	Refer to" 6.5 Installation Environment Requirements "
5	Mount the converter on a rechargeable lithium-ion battery system	Refer to" 6.4 Installation Position "
6	Electrical connections including DC (- battery), AC, ground, and communication connections (optional)	Refer to" 7 Electrical Connection "
7	Check before commissioning	Refer to" 8.3 Checking Before Commissioning "
8	Start the converter and configure the corresponding parameters	Refer to" 8.5 Commissioning Steps "
9	Troubleshooting	Refer to" 11.1 Troubleshooting "

5 Unpacking and Storage

5.1 Unpacking and Inspection

The DC/AC power converter unit undergoes thorough testing and strict inspection before delivery. However, damage may still occur during transportation.

- Upon receipt, inspect the packaging for any visible damage.
- After unpacking, check the internal contents for damage.
- Check the delivered items for quantity according to the packing list.

If any damage or missing items are found in the packaging or contents, please contact your dealer.

Do not throw away the original packaging box. It is recommended to store the DC/AC power converter unit in its original packaging if needed.

5.2 Identifying PCS

A nameplate is attached to one side of the PCS. It provides information on type of PCS, along with the most important specifications, marks of certification institutions, website and serial number which is available and identified by Sungrow.



figure 5-1 Nameplate of PCS (SC100CX)

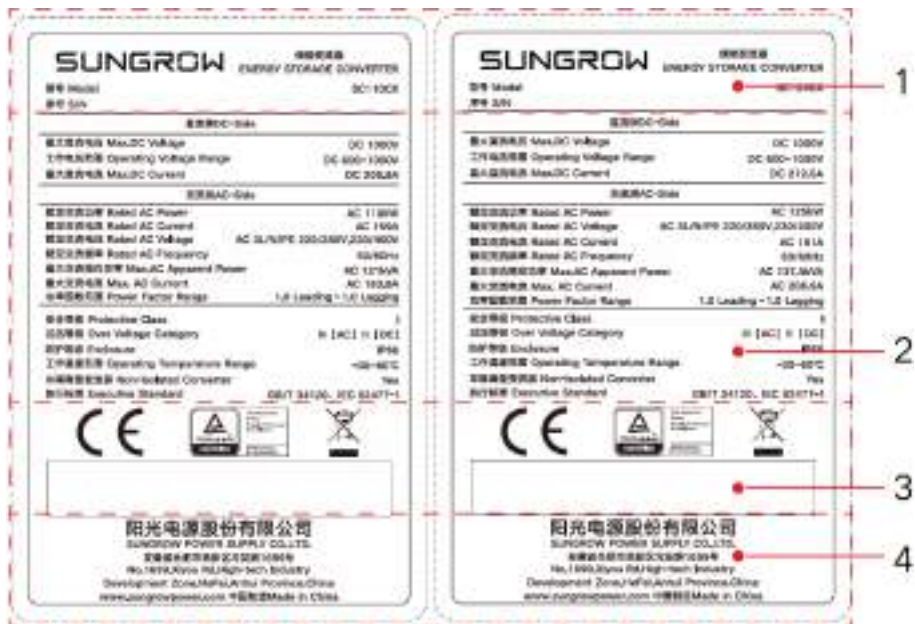





figure 5-2 Nameplate of PCS (SC110CX/SC125CX)

* Image shown here is for reference only. Actual product you receive may differ.

No.	Description
1	SUNGROW logo and product type
2	Technical data of PCS

No.	Description
3	Warning signs of PCS.
4	Company name, website and origin

table 5-1 Description of Icons on the Nameplate

Icon	Description
	This mark indicates that the product is allowed to be sold within the European Union.
	This mark indicates that the product has been certified by TÜV Rheinland for safety.
	This mark indicates that the product cannot be disposed of as household waste.

WARNING

The nameplate contains important parameter information related to PCS, which should be protected in various operations such as transportation, installation, maintenance, and overhaul. It is strictly forbidden to destroy or dismantle!

5.3 Storage of PCS

Store the PCS properly if it is not installed immediately. SUNGROW shall not be held liable for corrosion or internal component failure resulting from storage that does not comply with the requirements specified in this manual. The PCS must be enclosed in its original packaging, with desiccant placed inside.

- The PCS must be enclosed in its original packaging, with desiccant placed inside.
- Seal the packing box securely with adhesive tape.
- Store the PCS in a clean, dry environment and protect it against dust and moisture.
- Ambient temperature: -40°C to 70°C. Relative humidity: 0% to 95%, non-condensing.
- If one PCS is stacked on top of another, each stack must not exceed two layers.
- Keep the PCS away from corrosive chemicals to avoid possible corrosion.
- Periodically inspect the PCS for visible damage during storage (recommended every six months). Replace the packaging promptly if necessary.
- The packaging must remain upright.
- If the PCS is stored for six months or more, before connecting it to the energy storage system, a comprehensive inspection and test must be performed by the local installation or service team of SUNGROW.
- Avoid storing the PCS in places where corrosive gas or dust may be produced or accumulated, or in places within 30 km (20 miles) of saline-alkaline land or pollution-

generating industrial complex such as chemical plants and power plants (chemical gas class: 1C1, solid particle level: 1S2). Avoid storing the unit in environments contaminated with halogen and sulfur pollutants.

6 Installation

6.1 Inspection Before Installation

6.1.1 Deliverables Inspection

Check whether deliverables are complete against the attached packing list.

6.1.2 Check the Device

- Check that the actual product received is the same as the model ordered.
- Inspect the product and internal equipment to ensure that there is no damage.
- Check the RCD (Residual Current Monitoring Device) installation.

The PCS has an integrated RCD sensor based on the current Hall detection type and does not require an external connection. The following figure shows the installation position of the RCD.



figure 6-1 The installation position of the RCD



The PCS has a current sensor that detects the sum of the three-phase currents at the AC output (the sum of the three-phase currents during normal operation is 0). When the sum of the three-phase currents is not 0, the leakage current is considered to occur. When the detected leakage current exceeds the set value (the default value is 135mA, configurable), the PCS stops for protection and sends a fault message.

With an integrated universal current-sensitive residual current monitoring unit included, the PCS will disconnect immediately from the mains power once a fault current with a value exceeding the limit is detected.

However if an external residual current device (RCD) (type A is recommended) is mandatory, the switch must be triggered at the residual current. RCD of other specifications can also be used according to local standard. The recommended residual current is as follows.

PCS	Recommended Residual Current
SC100CX	120mA
SC110CX	132mA
SC125CX	150mA

If you find a problem or have questions, please contact the carrier or our company in time.

WARNING

Only products that are intact and free of any damage should be installed!

Before installation, make sure that:

- The product itself is intact and free of any damage.
- All equipment in the product is in good condition and free of any damage.









6.2 Transport

















Remove the DC/AC power converter unit from its packaging and move it to the target position. When moving the DC/AC power converter unit, follow the below instructions:

- Always pay attention to the weight of the DC/AC power converter unit.
- At least two people or suitable lifting equipment are required to move the DC/AC power converter unit.
- Do not release the unit until it is securely fastened.

6.3 Installation Tools

Gather the following tools before installation:

Type	Tool			
	Packaging tape	Marker	Measuring tape	Level
				
General tools	Utility knife	Multimeter Measurement	Protective clothing	Wrist strap
				

Type	Tool			
	Protective gloves	Dust mask	Earplugs	Goggles
				
	Insulated shoes	Vacuum cleaner		
				
	Hammer drill	Rubber mallet	Slotted screwdriver	Phillips screwdriver
				
Installation tool	Wrench Opening:16mm	Socket wrench	Wire cutter	
				
	crimping tool	RJ45 crimping tool	Wire stripper	Hydraulic pliers
				

- Other auxiliary tools or spare parts.

6.4 Installation Position

The PCS is installed on top of the battery container machine. As shown in the figure below:

**NOTICE**

PCS are installed into the cabinet through the guide rails. The front of PCS is fixed by screws, and the back is fixed by positioning pins.

NOTICE

PCS should not be installed outside the energy storage cabinet, such as on the wall, under the eaves, etc.

6.5 Installation Environment Requirements

6.5.1 Installation Site Requirement

- The climate environment and geological conditions, such as stress wave emission and underground water level, should be fully considered when selecting the installation site.
- The environment around the installation site should be dry and well ventilated.
- There should be no trees around the installation site to prevent branches or leaves blown off by heavy winds from blocking the door or air inlet of the energy storage system.
- The installation site should be away from areas where toxic and harmful gases are concentrated, and free from inflammable, explosive and corrosive materials.
- It is suggested the device be installed in a place away from the residential area. Ensure the distance and noise requirements specified by the local laws and regulations are met. If the requirements cannot be met due to geographical restrictions, use noise mitigation measures. For detailed solutions, consult with the designer or SUNGROW.
- Avoid installing the device in dusty environments with a large amount of dust, smoke, or floc. These particles may cling to the air inlets/outlets or heat sink of the device, thus impairing its heat dissipation performance or even getting it damaged.

- Avoid installing the device in places where corrosive gas or dust may be produced or accumulated, or in places within 30km (20 miles) of saline-alkaline land or pollution-generating industrial complex such as chemical plants and power plants (chemical gas class: 1C1, solid particle level: 1S2).
- Do not install the device in environments contaminated with halogen or sulfur pollutants.
- There are no underground facilities at the site.

NOTICE

Do not install the device in an environment with vibration and strong electromagnetic field. Strong-magnetic-field environments refer to places where magnetic field strength measures over 30 A/m.

6.5.2 PCS Cooling Requirements

Overview

PCS operating ambient temperature range : $-30^{\circ}\text{C}\sim 60^{\circ}\text{C}$. The cooling fan is designed in the body to make the PCS work within the normal operating temperature range. In addition, a diversion sealing plate is designed on the back of PCS to prevent the hot air flow from returning to the inlet.

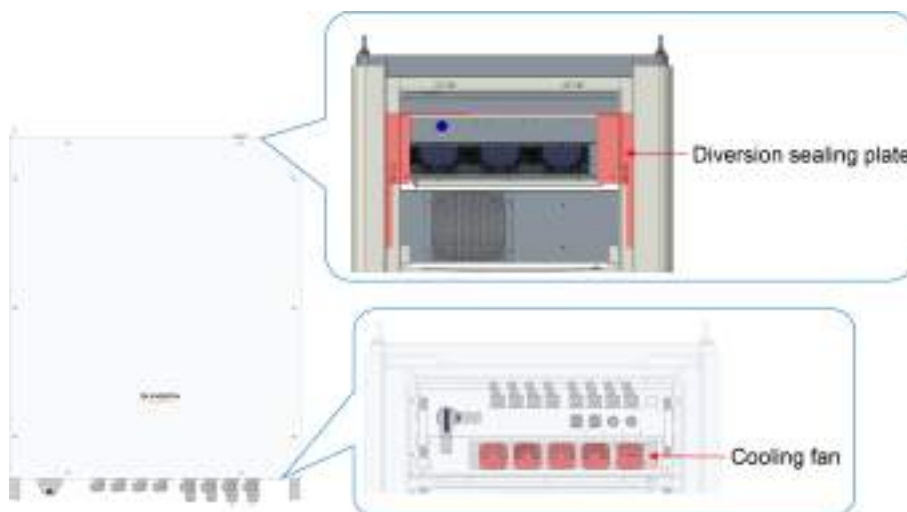

The figure is only an example, the specific subject to the actual.

Installation spacing requirement

A mesh plate must be installed at the front and back of a cabinet corresponding to PCS. The mesh plate area is $\geq 0.24\text{m}^2$, and the hole opening rate is $\geq 55\%$. The space requirements for PCS in the cabinet are as follows.

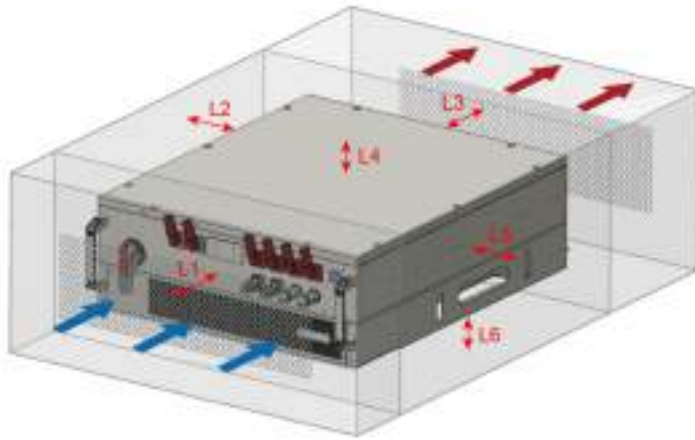

figure 6-2 Installation spacing requirement



The figure is only an example, the specific subject to the actual.

No.	Length
L1	≥100mm
L2	≥140mm
L3	≥400mm
L4	≥100mm
L5	≥140mm
L6	≥0mm

6.6 Installation Operation

PCS had been installed in the battery cabinet by the manufacturer before shipment, and installation operation is not required on site.

The following describes the fixation method of PCS in battery cabinet.

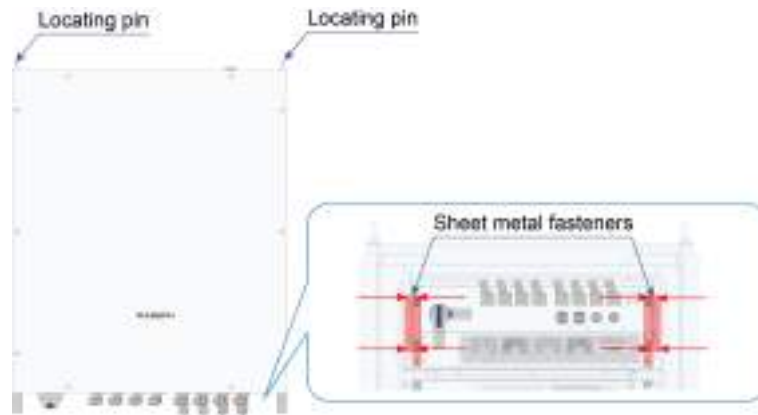

The figure is only an example, the specific subject to the actual.

Locating pin

Push the PCS into the system cabinet along the guide rails, until its locating pins align and engage with the slots. Ensure that it is securely positioned.

Sheet metal fasteners

Once the PCS is in place, fasten it to the system cabinet by securing the sheet metals at the front. Tighten the M6 bolts through the eight mounting holes at a torque of 7-8 N•m to fix the sheet metals in place.

Installation operation

1 Forklift transport

Manually move the machine to the fork of the forklift truck. The forklift truck slowly moves to the front of the battery cabinet and lifts the PCS to the installation level.



The figure is only an example, the specific subject to the actual.

NOTICE

- It is recommended that two persons perform this operation together.
- Wear protective tools, such as safety helmets and gloves, before handling PCS.

2 Install PCS

Two people gently push the PCS into the battery cabinet through the slide rails from the left and right sides of the PCS.



The figure is only an example, the specific subject to the actual.



During installation, align the positioning pins at the tail of the PCS with the positioning holes in the battery cabinet.

3 Install sheet metal fasteners

Remove the two front handles of the PCS, place the sheet metal fasteners behind the handles and fix them to the cabinet.



The figure is only an example, the specific subject to the actual.

7 Electrical Connection

7.1 Safety Instructions

7.1.1 General Rules

DANGER

High voltage! Electrical shock!

- Do not touch the live component!
- Ensure that both the AC and DC sides are voltage-free before installation.
- Do not put flammable materials near the product.

WARNING

- Observe all the country-specific standards and regulations.
- Connect the product to the grid only after gaining approval from the local grid operator.

WARNING

**Only qualified electricians can perform the operations described in this chapter.
Follow all instructions for electrical connections during wiring.**

WARNING

Ensure all AC circuit breakers and DC load switches are open before electrical connection.

WARNING

Sand and moisture penetration may affect the performance of electric devices inside the product!

- Do not perform electrical connection in sandy seasons, or when the ambient relative humidity is above 95%.
- Perform electrical connection on fine days.

WARNING

**Improper torque may cause fire at the connection point!
Fix the bolts by strictly following the torque requirements in this manual during electrical connection.**

⚠ WARNING

Improperly small bending radius or excessive intertwining may damage the fiber optic cable!

When using the fiber optic cable as the communication cable, follow the manufacturer's specifications for the minimum allowable bending radius.

⚠ WARNING

Only qualified electricians can perform the electrical connection. Qualified electricians should meet the related requirements listed in "Safety Instructions" in this manual. SUNGROW shall hold no liability for any personal injury or property loss caused by ignorance of the safety instructions.

⚠ WARNING

Ensure the electrical insulation is completed before laying the cables. Follow the EMC (Electro-Magnetic Compatibility) regulation and lay the power cable and communication cable in different layers. Provide support and protection to the cables to reduce stress when necessary.

⚠ WARNING

Strictly follow all the instructions when connecting the cables.

⚠ WARNING

During operation, personnel should wear protective earplugs.

NOTICE

- **The installation plan for the product must be designed in accordance with national and local standards and regulations.**
- **SUNGROW shall hold no liability for the product or system fault caused by ignorance of the description in this manual.**



Select fiber optic cables as the external communication cable to lower signal interference.



Check all air inlets and outlets for blockage.

7.1.2 Five Safety Rules

During electrical connections and other operations on the internal devices, observe the following five safety rules:

- Disconnect all external connections and the DC/AC power converter unit internal power supply.
- Avoid accidental reconnection to power.
- Verify that no voltage or current is present with appropriate measuring devices.
- Make necessary grounding connections.
- Cover possible live parts to avoid accidental contact.

7.2 Terminal Description

All electrical terminals and ports of the PCS are located on the wiring panel, as shown below:

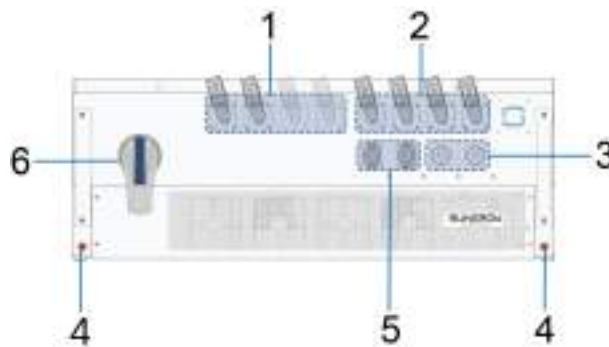

figure 7-1 Wiring Panel Introduction

* Figures are for reference only. The product you have received may differ.

No.	Item	Description	Wire Diameter
1	DC input terminal	BAT1+ /BAT1- (/BAT2 + /BAT2-)	2/0AWG(67.4321mm ²)copper cable
2	AC output terminal	A/B/C/N	2/0AWG(67.4321mm ²)copper cable
3	Communication port	Ethernet1/ Ethernet2	CAT6A communication cable
4	Secondary grounding terminal	Terminal for secondary protective grounding	5AWG(16.7657mm ²)yellow-green wire and cable

No.	Item	Description	Wire Diameter
5	Communication port	COM1	20AWG*2C communication cable
		COM2	22AWG communication cable
6	DC switch	Used to safely disconnect the PCS from the battery	-

7.3 Battery Connection

7.3.1 Precautions

Always follow the safety instructions in this manual. In order to avoid personal injury and property damage that may occur during installation or operation, and extend the service life of this product, please carefully read all safety instructions.

Improper or incorrect use may result in:

- A threat to the life and personal safety of the operator or third parties;
- Damage to the energy storage system or other property of the operator or third party.



- The safety precautions in this manual do not cover all specifications to be followed, and all operations should be performed based on the site conditions.
- SUNGROW shall not be liable for any loss arising from failure to follow the safety precautions in the manual.

WARNING

- **While installing the device with hazardous voltage, follow relevant regulations and local installation safety guidelines.**
 - **Please observe the regulations on the correct use of tools and personal protective equipment.**
 - **All connections must be carried out with distinctive guidance. Any guess and ambiguous attempts must be prohibited.**
 - **Tools with an insulating protective coating must be used.**
- Connecting cables should meet the voltage and current requirements.
 - All connectors must be safe and reliable to avoid loosening or virtual contact. They must be corrosion-resistant, wear-resistant and shock-proof.
 - All connections must comply with the requirements of relevant national standards to prevent arc discharge in any form.
 - The connections of internal batteries must be equipped with anti-vibration and antiloosening devices. Temperature, voltage and current sensors must be connected safely and

reliably, to prevent loosening, ageing and extrusion. All sensor cables must be free of metal exposure.

- Any type of short circuit should be prevented in the connection process.
- Operators must use this product with personal protective equipment.
- All connections must be carried out with distinctive guidance. Any guess and ambiguous attempts must be prohibited.
- Key connections must be correct, reliable (without loosening) and in good contact, without short-circuits.
- All the finished connections must be measured and confirmed one by one.
- All connections must not be in contact with the casing or other components or shortcircuited.
- If there are other uncertain factors, please consult the after-sales technicians of SUN-GROW before any operation.

7.3.2 Cable Connection

The application of a PCS in a rechargeable lithium-ion battery system is taken as an example to introduce the wiring between the PCS and the battery side.

Tools



figure 7-2 Installation Tools

Operating process

- Step 1** Before connecting the power cable, put on insulated shoes and safety gloves. Before connecting the power cable between the Packs, disconnect the wirings between the Pack and the PCS first.
- Step 2** Install the fuse and properly insert the plug that comes with the fuse into the battery base.
- Step 3** Connect the power cable between the Packs. The positive of the power cable between the Packs has been secured on the Rack, and the negative is fastened on the side bracket through the quick-connect clamp and cable tie.

⚠ WARNING

When the aviation connector is connected in place, you will hear an audible click. Please make sure the connector is firmly connected.

NOTICE

When connecting the power cable between Packs, you need to take down the negative of the power cable from the clamp on the side panel and insert it into the negative base.

Step 4 Connect the power cable between the Pack and the PCS:

Connect the power cable of 0.5C product between the Pack and the PCS

- 1 Connect the BAT+ of Pack1# to the BAT+ of PCS;
- 2 Connect the BAT- of Pack4# to the BAT- of PCS.

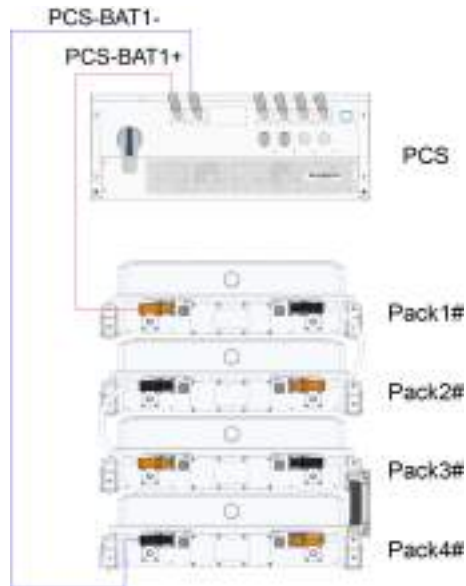

figure 7-3 Wiring Diagram

Connect the power cable of 0.25C product between the Pack and the PCS

- 1 Connect the BAT+ of Pack1# to the BAT1+ of PCS;
- 2 Connect the BAT- of Pack4# to the BAT1- of PCS;
- 3 Connect the BAT+ of Pack5# to the BAT2+ of PCS;
- 4 Connect the BAT- of Pack8# to the BAT2- of PCS;

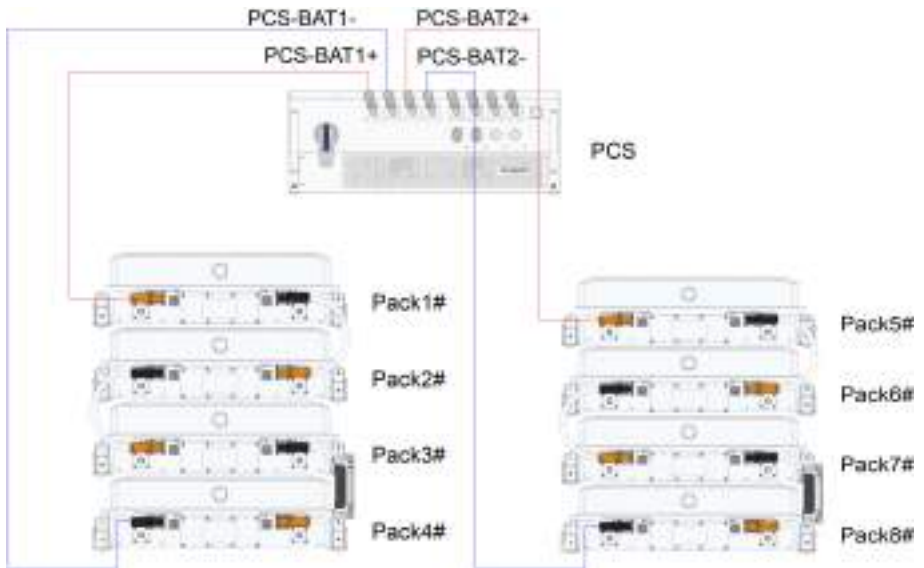

figure 7-4 Wiring Diagram

⚠ WARNING

When the threaded plug is connected in place to the PCS DC wiring terminal, you will hear an audible click. Please make sure the plug is securely connected.

-- End

Connector requirements



figure 7-5 Plug Indication



figure 7-6 Socket Indication

- Press the lock button on the connector to insert or remove the connector from the PCS.
- Initial IP protection requirement: IP67 (connected with socket).

⚠ WARNING

There is a risk of touching the interface of the connecting socket when the connector is unplugged. Do not touch the connector socket in despite of its insulation ability.

⚠ WARNING

No secondary wiring of the connector is allowed.

7.4 Steps for AC Wiring

7.4.1 Safety Precautions

⚠ WARNING

Accidental contact with a live terminal can result in a fatal electric shock hazard!

- Make sure that the DC switch of the energy storage PCS is in the disconnected state, and that the terminal is not electrified.
- Connections to the grid must be permitted by the relevant authorities and all grid-related safety directives must be complied with.

⚠ WARNING

- When connecting AC equipment, disconnect the upstream AC side circuit breaker to ensure that the contact terminals are free of voltage.
- Connections to the grid can only be made with the approval of the utility grid and all relevant safety instructions followed.
- The AC output is not grounded inside the device.
- DC and AC circuits are isolated from the enclosure and require an installer to connect the system if required by the relevant national electrical code.

7.4.2 Wiring Steps

⚠ DANGER

High voltage inside the PCS!

Before electrical connection, make sure all cables are voltage-free.

Do not turn on the AC circuit breaker until all electrical connections of the PCS are complete.

Step 1 Turn off the upstream AC circuit breaker and measure with a multimeter to ensure no voltage is present at the terminals.

Step 2 Lead the cable to the PCS AC wiring area through the cable inlet.

Step 3 Make sure the wires of the AC cable are connected properly in the correct position.



Step 4 Crimp the threaded plugs of the cable to the corresponding sockets by following the correct phase sequence.

⚠ WARNING

When the threaded cable plug is connected in place, you will hear an audible click. Please make sure the cable plugs are secured.

Step 5 Pull the cable backward slightly after wiring to ensure that the cable is long enough.

-- End

Connector requirements



figure 7-7 Plug Indication



figure 7-8 Socket Indication

- Press the lock button on the connector to insert or remove the connector from the PCS.
- Initial IP protection requirement: IP67 (connected with socket).

⚠ WARNING

There is a risk of touching the interface of the connecting socket when the connector is unplugged. Do not touch the connector socket in despite of its insulation ability.

⚠ WARNING

No secondary wiring of the connector is allowed.

7.5 Communication Connection

Two Ethernet ports (Ethernet1 and Ethernet2) and two COM ports (COM1, COM2 and COM3) are provided on the PCS wiring panel. The position and description of the ports are shown below:

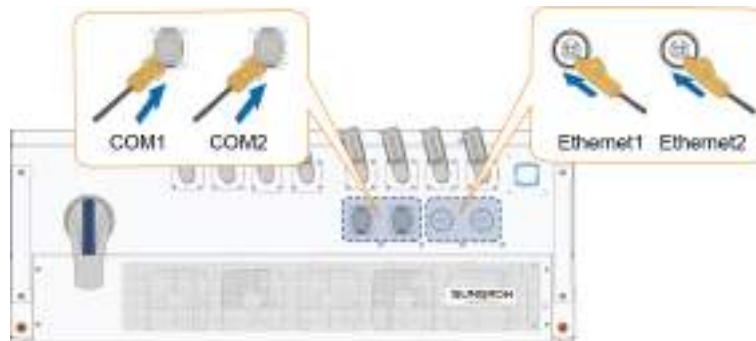

figure 7-9 Product Exterior

Network port	Description
COM1	Connected to the secondary communication wiring
COM2	Connected to daisy chain communication of Racks
Ethernet1/ Ethernet2	Connected to LC or reserved (DRM communication for Australia)



- COM1 and Ethernet1 port communicate with LC in the ST200CS system.
- COM2 port provides power and communication to the BMS.
- Ethernet1 is the external communication port of PCS and is connected by network cables.
- Ethernet2 port is a DRM interface. It is used with Australian DRM equipment and is connected by network cable.

7.6 Grounding

The secondary protective grounding terminals are set at the two ends of the PCS wiring panel. Be sure to connect the grounding cable to this grounding terminal to allow reliable grounding. Make sure the grounding resistance is smaller than 10 ohms.

**⚠ WARNING**

During product use, avoid DC positive-/negative-to-ground short circuits, and short circuits between positive and negative. Otherwise, it may lead to serious damages to the PCS!

In case a short circuit fault has occurred, the whole PCS should be replaced!

⚠ WARNING

In Europe and Asia Pacific, this type of secondary protective grounding cannot be taken as a substitute for that done through a terminal in AC wiring. Both should be reliably grounded. Otherwise, SUNGROW will assume no responsibility for any possible outcomes incurred therefrom.

NOTICE

In other regions (such as North America), secondary protective grounding can be implemented in accordance with the applicable local and national standards.

8 Commissioning

8.1 Safety Instructions

DANGER

High voltage! Electric shock!

- Wear proper protection equipment before all operations on the device.
- Do not touch the live terminals or conductors.
- Respect all safety instructions attached on the device and described in this manual.
- Respect all safety instructions prescribed by the manufacturer of devices connected to the MV power converter.

WARNING

The MV power converter can only be connected to the grid with prior approval from the local grid operator. Grid connection operations must be performed by qualified personnel.

WARNING

After the MV power converter is operating, make sure there are no flammable materials at least 5 meters around the installation site.

Local/national standards about the min. electric clearance around the MV power converter should be respected.

CAUTION

Make sure the installation is correct and no spare parts or tools are left inside the device.

NOTICE

Close the doors of the MV power converter and the internal devices if the commissioning process is stopped.

8.2 Commissioning Requirements

Before commissioning, the installation of the equipment should be thoroughly checked again.

- Make sure all connecting cables are securely attached and all screws are tightened in place.
- Make sure that the DC side voltage meets the converter requirements and that the polarity is correct.
- Make sure that the AC side voltage meets the converter requirements.
- Ensure that all connections to the system comply with the requirements of the relevant standards and specifications.
- Make sure the system is well grounded. The ground resistance is decisive for the safety of the entire system, so it is important to ensure that the ground resistance meets the requirements (the ground resistance must not be higher than 10 Ω) before the first test run.

WARNING

Make sure the Emergency Stop button on the monitoring window is in a loose state, and then disconnect the DC side battery switch.

NOTICE

All operations during the commissioning process must be carried out by professional electrical personnel. No individual is allowed to operate without authorization.



In order to ensure the normal and smooth operation of PCS for the first time, it is recommended to select a sunny and stable weather condition to test run the equipment.

8.3 Checking Before Commissioning

8.3.1 Checking Cable Connection

- Check cables for any possible damages or cracks.
- Check that all cables are connected securely according to the cable connection diagram. Adjust the cable connection if necessary.
- Ensure all cable connections are firmly enough. Fix the bolts if necessary.
- Check the PE equipotential connection. Ensure the PE ground point of internal devices has been connected to the equipotential connection point in the MV power converter and properly grounded.

8.3.2 Check PCS

- Make sure the AC and DC switches are disconnected.
- Make sure the emergency stop button handles the release state.
- Check and ensure that the various electrical switches and buttons in the front and rear stages of PCS are flexible and meet the requirements of the specification.

8.3.3 Checking the Batteries

WARNING

Make sure the measuring devices are connected and used correctly. There will be electric arc if otherwise.

WARNING

DC side voltage should not exceed the maximum allowable DC input voltage of the MV power converter.

Excessively high DC voltage may damage the MV power converter, and even cause safety incidents.

Ensure the polarity correctness. If otherwise, serious consequence may follow.

Check the battery before starting the device to make sure the max. voltage of the battery meets the requirement.

- Record field-measured data accurately.
- Make sure the positive and negative polarities are correct. Incorrect polarity may damage the module seriously.
- Measure the resistance of cables (between the terminal box and the MV power converter) by ohmmeter. Accurately record all measured data.

8.3.4 Checking Grid Voltage

- Measure accurately the grid 3-phase line-to-line voltage: A-B, A-C, and B-C. The measured data should not exceed the grid permissible value and the three-phase voltages should be balance.



Adjust the transfer ratio of the transformer by qualified personnel if the grid voltage deviation is serious.

- Measure and record the grid frequency. The measured data should not exceed the grid permissible value.
- Measure the THD and check the curve if possible. The PCS may not operate stop if the THD is serious.
- Record accurately all the measured data.

*Find those requirements in 13 Appendix.

8.4 Preparation Before Booting

When all the above items have been checked and confirmed to meet the requirements, prepare for start-up.

- Install the protective net at the wiring that was removed during wiring to its original position to ensure that it is firmly installed.
- Clean up the equipment site to ensure that the site is clean and free of flammable, explosive and other items.
- Ensure that the equipment installation site is properly ventilated.
- Check the various electrical switches and buttons of the equipment again to ensure that the operation is flexible and meets the requirements of the specification.

8.5 Commissioning Steps

If all of the above items are satisfied, follow the steps below to start power converter unit for the first time.

Step 1 Make sure that all of the above items meet the requirements.

Step 2 Close the external AC disconnect and circuit breaker and put them into the power grid.

Step 3 Rotate the DC switch of the converter wiring panel to the "ON" position.

Step 4 A communication connection is established with power converter unit using the LC controller to set the initial parameters. After initializing the device, send the relevant details such as the boot command.

Set the initial parameters of LC controller:



- Set the IP address of the PC to be in the same network segment as that of the device.
- Connect the PC to the ETH2 port of the device.
- The default IP address of the ETH2 port is 192.168.13.100, and the IP of the PC can be configured as 192.168.13.99, and the subnet mask is 255.255.255.0.

When logging into the LC, there are four types of users: **oprater**, **administrator**, **developer** and **superadministrator**.



For the convenience of initial on-site debugging, the product is equipped with a local Bluetooth module. It is only used in conjunction with nearby iSolarCloud app during initial debugging. After debugging is complete, it can be disabled as needed.

When logging into the iSolarCloud app:

- The default username is user, initial password is pw1111. Change the initial password for account security.
- The username for the R&D account is admin. Please contact SUNGROW Customer Service for the password.

Step 5 power converter unit feeds AC power to the grid and enters the operating state.

-- End

9 Disconnecting, Dismantling and Disposing the PCS

9.1 Shutdown

For maintenance work or any repair work, the converter must be switched off. In normal operation, there is no need to shut down.

In order to disconnect the converter from the AC and DC power sources, you should do the following. Otherwise, you will be at risk of deadly high voltage, or the device will be damaged as a result.

Step 1 Disconnect the external AC circuit breaker and prevent it from reconnecting.

Step 2 Turn off the pre-amp DC circuit breaker. Rotate the DC switch of the converter wiring panel to the "OFF" position.

NOTICE

Please strictly follow the order of the above procedures. Otherwise, there will be a risk of electric shock.

Step 3 Wait about 15 minutes until the internal discharge of the converter is finished.

Step 4 Measure the AC ground voltage on the AC terminal to confirm that there is no voltage on the AC output of the converter on the AC circuit breaker.

Step 5 Loosen the screws to remove the AC cable.

Step 6 Disconnect the DC cable from the converter.

-- End

9.2 Dismantling the PCS

Refer to to dismantle the PCS in reverse steps.

⚠ WARNING

When maintaining the PCS on site, the equipment needs to be removed from the container. During the disassembly process of the equipment, attention should be paid to electrical safety protection and construction safety protection.

Step 1 Before disassembling the PCS, check whether there is sufficient construction space around it.

Step 2 After turning off the power switch of the battery container, wait for 15 minutes before starting the operation. Use a multimeter to measure the voltage at the AC and DC terminals. Only after confirming that the power is off can the operation be carried out.



When disassembling and maintaining the converter on site, it is necessary to comprehensively consider the maintenance location and the weight of the equipment, and arrange a reasonable transportation and support method based on the center of gravity position.

Step 3 Remove the liquid cooling water pipe, strong and weak current, grounding wire, installation screws, etc. in sequence, and then pull out the PCS. If coolant overflows when disassembling the quick connector, it must be cleaned up thoroughly.

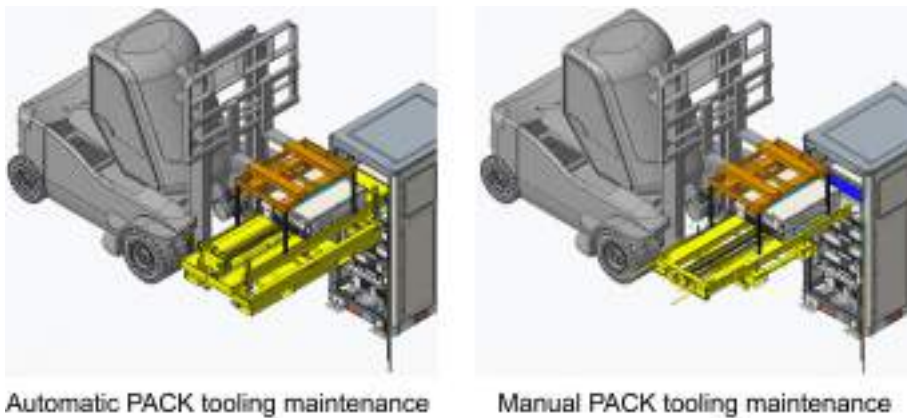

figure 9-1 Maintenance of PCS

-- End

9.3 Disposing the PCS

Users should take the responsibility for the disposal of the PCS.

NOTICE

Some parts and devices in the PCS, such as the LCD display, batteries, capacitors, may cause environment pollution. Users must comply with the related local regulations to avoid pollution.

10 iSolarCloud APP

10.1 Brief Introduction

The iSolarCloud APP can establish communication connection to the PCS via the Bluetooth, thereby achieving near-end maintenance on the PCS. Users can use the APP to view basic information, alarms, and events, set parameters, or download logs, etc.

In case the communication module Eye or WiFi is available, the iSolarcloud APP can also establish communication connection to the PCS via the mobile data or WiFi, thereby achieving remote maintenance on the PCS.



- This manual describes only how to achieve near-end maintenance via the Bluetooth connection. For remote maintenance through the Eye or WiFi, refer to the related manuals in the delivery scope.
- Screenshots in this manual are based on the Android system V2.1.4, and the actual interfaces may differ.

10.2 Download and Install

Method 1

Download and install the APP through the following application stores:

- MyApp (Android, mainland China users)
- Google Play (Android, users other than mainland China ones)
- APP store (iOS)

Method 2

Scan the following QR code to download and install the APP according to the prompt information.



The APP icon appears on the home screen after installation.



10.3 Login

10.3.1 Requirements

The following items should meet requirements:

- The AC and DC sides or the AC side of the DC/AC power converter unit is powered-on.
- The mobile phone is within 5m away from the DC/AC power converter unit and there are no obstructions in between.
- The Bluetooth function of the mobile phone is enabled.

10.3.2 Login Steps

Step 1 Open the APP to enter the login interface, and click **Local Access** to enter the next screen.

Step 2 Select an approach to connect the PCS on the “Bluetooth Search” pop-up. You may:

- Choose the PCS to be connected according to the SN indicated on the nameplate of the PCS. Such as:
 - 1 Click **Manual Connection**.
 - 2 Choose **Others** under “Bluetooth” at the bottom of the interface.

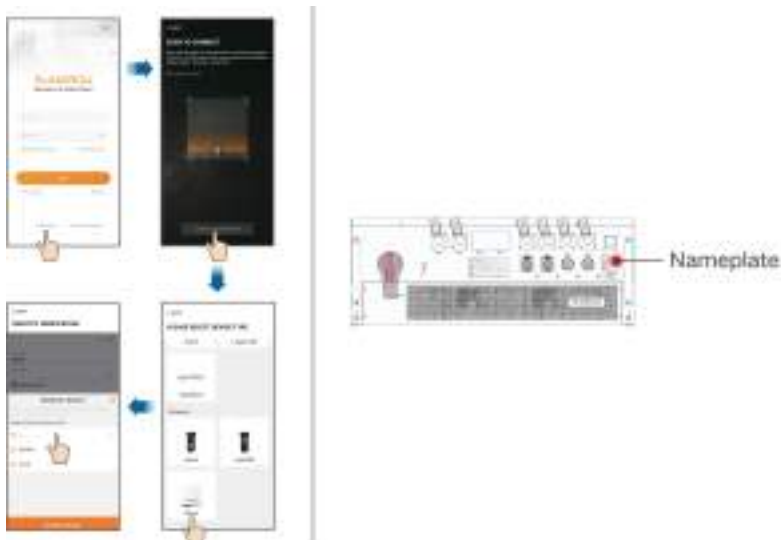

- 3 Enter the “Identity Verification” interface, and select the SN code to connect the PCS on the “Bluetooth Search” pop-up.

Step 3 Enter the account and the password after PCS is successfully connected.



The default username is **user** and the initial password is **pw1111**. Please change the password as soon as possible to ensure account security.

Step 4 If the PCS has not been initialized, you will then enter the interface for quick settings of initialize protection parameter. After completing the settings, click **TURN ON DEVICE** and the device will be initialized. The App will send startup instructions and the device will start and operate.

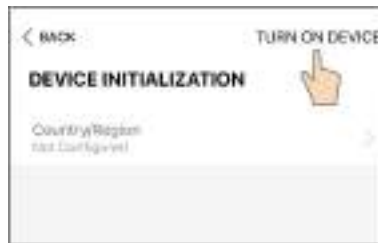

figure 10-1 Quick settings of initialize protection parameter

NOTICE

If the country code is not set correctly during commissioning, reset the protection parameters. There may be faults unless this is done.

Step 5 If the PCS is initialized, the app automatically turns to its homepage

-- End

10.4 Introduction to Cybersecurity Mode

The APP has two modes: a cybersecurity mode and a non-cybersecurity mode. The following are the differences in permissions between these two modes.

Cybersecurity mode

User type	Account	Password	Operation permission
Administrator	administrator	pw1111	Manage all users: including creating, viewing or deleting users, and resetting account passwords. Support the activation of session management and operation and maintenance modes.
Developer account	develop	Obtain S/N generation through customer authorization	If there is an administrator user on the device, the administrator needs to enable the operation and maintenance mode before logging in with the developer account.
Ordinary user	user	pw1111	Only system monitoring permissions and simple setting permissions are available. Such as overview, equipment monitoring and viewing of some historical data.
Operation and maintenance users	admin	pw8888	All operations and functional descriptions in this manual are based on the permissions of the operation and maintenance users.

Non-cybersecurity mode

User type	Account	Password	Operation permission
Developer account	admin	Dynamic password	Permissions for setting parameters related to research and development; The R&D debugging can set the network security mode and enable the remote maintenance function.
Operation and maintenance users	admin	pw8888	All operations and functional descriptions in this manual are based on the permissions of the operation and maintenance users.
Ordinary user	user	pw1111	Only system monitoring permissions and simple setting permissions are available. Such as overview, equipment monitoring and viewing of some historical data.



- In the network security mode, the system will force users to change their default passwords. In non-network security mode, the system does not force password changes, but it is still recommended that users change their default passwords as soon as possible to enhance security. Not changing the initial password may lead to password leakage. Long-term use of the initial password increases the risk of theft and cracking. Password loss may prevent users from accessing the device, both of which may cause losses to the power station. Any losses resulting from this shall be borne by the users themselves.
- It is recommended that users update their passwords regularly. After changing the password, please remember it well to ensure the security of your account.
- The password length should be 8 to 32 characters and consist of three or more of the following: capital letters, lowercase letters, numbers, and special symbols.
- The user interfaces used by different user types vary. This manual describes all operations based on the permissions of the operation and maintenance user role (admin).

10.5 Cybersecurity Mode Switch

If the user needs to turn on the cybersecurity mode switch, they can refer to the following operations.

Step 1 Please click “**Settings**→**Operation parameters**→**Regular parameters**→**Network security mode**” to turn on the cybersecurity mode switch.

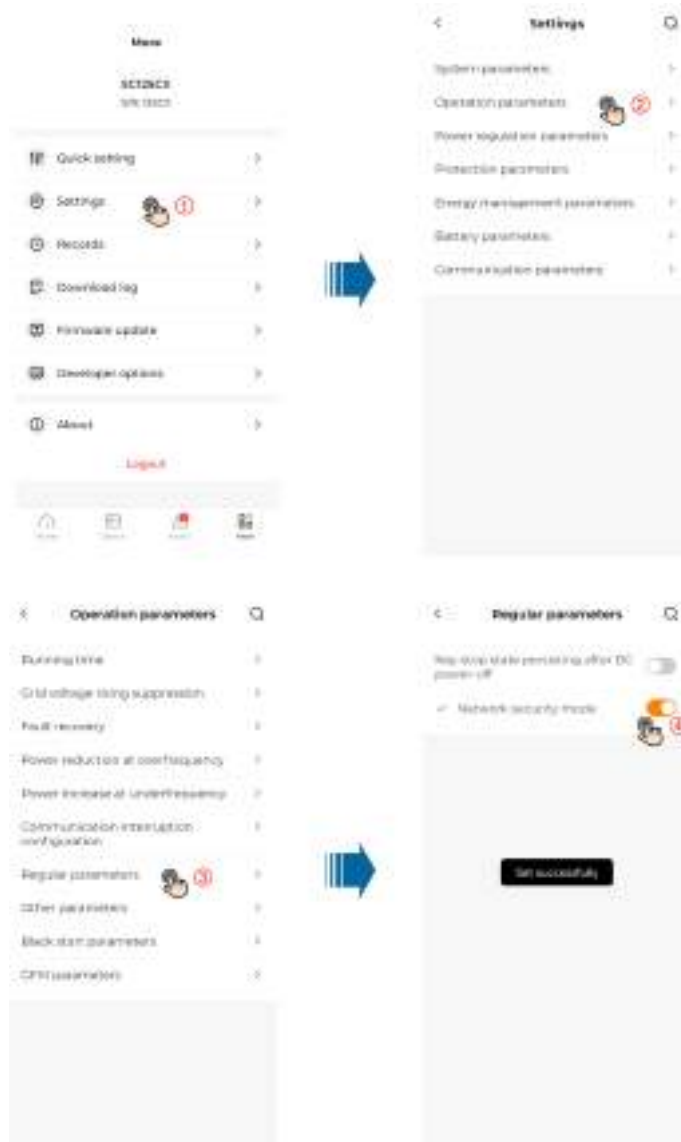

-- End

10.6 Test and Adjustment (iSolarCloud App)

For device commissioning operations, please refer to the [iSolarCloud App User Manual](#). Alternatively, you can scan the QR code below to access the manual.



10.7 Firmware Update

To avoid download failure due to poor on-site network signal, it is recommended to download the firmware package to the mobile device in advance.

Step 1 Enable the "Mobile data" of the mobile device.

Step 2 Open the App, enter the account and password on the login interface. Tap **Login** to enter the home interface.

Step 3 Tap "**More**→**Firmware Download**" to enter corresponding interface on which you can view the device list.

Step 4 Select the device model before downloading the firmware. Tap the device name in the device list to enter the firmware upgrade package detail interface, and upgrade package to download it.

Step 5 Return to the **Firmware Download** interface, tap in the upper right corner of the interface to view the downloaded firmware upgrade package.



Step 6 Login the App via local access mode.

Step 7 Tap **More** on the App home interface and then tap **Firmware Update**.

Step 8 Tap the upgrade package file, a prompt box will pop up asking whether to upgrade the firmware with the file, tap **CONFIRM** to perform the firmware upgrade.

Step 9 Wait for the file to be uploaded. When the upgrade is finished, a message is displayed indicating that the upgrade is completed. Tap **Complete** to end the upgrade.



-- End

11 Troubleshooting and Maintenance

11.1 Troubleshooting

In case a fault has occurred with the DC/AC power converter unit, you can check the fault information on the iSolarCloud App.

The fault codes and corresponding inspection methods are shown below.

table 11-1 DC/AC power converter unit & BESS Side

Type	Fault Name	Corrective measures
	DC bus under-voltage	If the fault occurs repeatedly, please contact SUNGROW Customer Service.
	Device Abnormality	Check whether bus over-voltage threshold is correctly set. If the setting is correct and the fault persists, please contact SUNGROW Customer Service.
Fault code 1	Grid under-voltage	<p>The fault is caused as the grid voltage is lower than the permissible range. The converter can operate normally when the grid recovers.</p> <ol style="list-style-type: none">1 Measure the actual grid voltage; and If the grid voltage is lower than the permissible range, ask utility grid company for solution.2 Check whether the protection parameters are appropriately set via the APP or the LCD screen.3 Check whether the AC cable is firmly connected in place.4 If the fault does not arise for the aforementioned reason and still cannot be resolved, please contact SUNGROW Customer Service.

Type	Fault Name	Corrective measures
		<p>Fault occurred because the grid voltage exceeds the permissible range. Converter can operate normally when the grid recovers.</p> <ol style="list-style-type: none"> 1 Measure the actual grid voltage. If the grid voltage is higher than the set value, please contact your local power company for help. 2 Check whether the protection parameters are appropriately set via the APP. Modify the over-voltage protection values with the consent of your local electric power operator. 3 If the fault does not arise for the aforementioned reason and still cannot be resolved, please contact SUNGROW Customer Service.
	Grid over-voltage	
	Grid under-frequency	<p>Check the grid frequency.</p> <p>If the grid frequency is lower than the permissible range, ask utility grid company for solution.</p>
	Grid over-frequency	<p>Check the grid frequency.</p> <p>If the grid voltage exceeds the inverter permissible range, ask utility grid company for solution.</p>
	Device Abnormality	<p>Wait for inverter recovery.</p> <p>If the fault still exists, please contact Sungrow Customer Service.</p>
	Grid Power Outage	<p>Generally, the device is reconnected to the grid after the grid recovers to normal. If the fault occurs repeatedly:</p> <ol style="list-style-type: none"> 1 Check if the grid power supply is normal. 2 Check if AC cables are all firmly connected. 3 Check if AC cables are connected to the correct terminals (with or without live line and reverse connection). 4 If the fault still exists, please contact Sungrow Customer Service.

Type	Fault Name	Corrective measures
		Generally, the converter will be reconnected to the grid after the grid returns to normal. If the fault occurs repeatedly:
	10 Minutes Grid Over-voltage	<ol style="list-style-type: none"> 1 Measure the actual grid voltage, and please contact the local electric Power company for solutions if the grid voltage is higher than the set value. 2 Check whether the protection parameters are appropriately set via the APP. 3 Check whether the cross-sectional area of the AC cable meets the requirement. 4 If the fault is not caused by the foregoing reasons and still exists, please contact Sungrow Customer Service.
		Generally, the device is reconnected to the grid after the inner temperature or module temperature recovers to normal. If the fault occurs repeatedly:
	Power power module over-temperature	<ol style="list-style-type: none"> 1 Check whether the temperature displayed on LCD or App is excessively high. 2 Check if the device is placed in a well-ventilated place. 3 Check if the device is in direct sunlight. If so, please shield it. 4 Check if the fans operate normally. Replace them if otherwise. 5 If the fault still exists, please contact Sungrow Customer Service.
	Leakage current exceeds limit	<ol style="list-style-type: none"> 1 Check if the battery is exposed to rainy or humid weather. If so, there is no need to worry. 2 Check for any poor contacts in the battery. 3 Check whether protection thresholds are properly set in the APP. 4 If the fault is not caused by the foregoing reason and still exists, Please contact Sungrow Customer Service.
	Output overload	Please contact Sungrow Customer Service

Type	Fault Name	Corrective measures
	Fan Fault	<p>Wait for the system to return to normal:</p> <p>Disconnect the AC test switch and DC switch. If there is a battery, the switch on the battery side must be switched off. Wait 15 minutes, then close the AC and DC switches in turn, and restart the system. If the fault persists, please contact the Customer Service.</p>
	DC C-over	<p>Generally, the fault will be cleared automatically and no further operation is required. If the fault persists, please contact Sungrow Customer Service.</p>
	AC over-current	<p>The inverter detects AC instantaneous over-current. The converter will automatically recover several seconds later after the grid current is reduced.</p>
	Ambient over-temperature	<p>Generally, the device is reconnected to the grid after the inner temperature or module temperature recovers to normal. If the fault occurs repeatedly:</p> <ol style="list-style-type: none"> 1 Check whether the temperature displayed on LCD or App is excessively high. 2 Check if the device is placed in a well-ventilated place. 3 Check if the device is in direct sunlight. If so, please shield it. 4 Check if the fans operate normally. Replace them if otherwise. 5 If the fault still exists, please contact Sungrow Customer Service.
	Device Abnormality	<p>Generally, the fault automatically recovers without processing. If the fault occurs repeatedly, please contact Sungrow Customer Service.</p>
	Over-voltage Protection	<p>Consult battery manufacturer for a solution.</p>
	Low Voltage Protection	<p>Consult battery manufacturer for a solution.</p>
Fault code 2	System low insulation resistance	<p>If the fault occurs repeatedly, please contact Sungrow Customer Service.</p>
	AC SPD Fault	<p>Check whether the SPD is loosely connected or damaged. Replace it if it is damaged.</p>

Type	Fault Name	Corrective measures
	Analog Offset Abnormal	<ol style="list-style-type: none"> 1 Reboot the device. 2 Check the internal wiring to make sure there are no loose connections. 3 If the fault is not caused by the foregoing reasons and still exists, contact Sungrow Customer Service.
	Abnormal Battery Connection	<ol style="list-style-type: none"> 1 Check and correct polarity of cable connection between the battery and the inverter. 2 If the fault is not caused by the foregoing reasons and still exists, please contact Sungrow Customer Service.
	AC current imbalance	This fault is caused by 3-phase current unbalance, and it will automatically recover without manual operation; if the fault occurs repeatedly, please contact Sungrow Customer Service.
	DC contactor failure	Wait for the inverter to return to normal. If the fault persists, it is usually due to contactor fault or voltage sampling abnormal on the DC side. Please contact SUNGROW Customer Service.
	DC SPD Fault	Check whether the SPD is loosely connected or damaged. Replace it if it is damaged.
	DC Soft Start Failure	If the fault persists after the device is restarted, please contact Sungrow Customer Service.
	DC Injection Exceeded	After fault shutdown, the inverter will automatically restart. If fault occurs repeatedly, please contact Sungrow Customer Service.
	Duplicate Address Code	<p>Wait for the system to return to normal:</p> <p>Disconnect the AC test switch and DC switch. If there is a battery, the switch on the battery side must be switched off. Wait 15 minutes, then close the AC and DC switches in turn, and restart the system. If the fault persists, please contact the Customer Service.</p>
	Parallel Machine Communication Failure	<ol style="list-style-type: none"> 1 Try to power down and reboot the device. 2 Check the parallel device communication line for any loose connections. 3 If the fault is not caused by the foregoing reasons and still exists, contact Sungrow Customer Service.

Type	Fault Name	Corrective measures
		Generally, the inverter will be reconnected to the grid after the grid returns to normal, and if the fault occurs repeatedly:
	Vac Unbal	<ol style="list-style-type: none"> 1 Measure the actual grid voltage, and contact the electric power company in case the grid voltage unbalance is higher than the set value. 2 Check, on the App, whether the parameter grid voltage unbalance is set to an appropriate value. 3 If the fault is not caused by the foregoing reason and still exists, contact Sungrow Customer Service.
	BMS Communication Fault	Check the communication line to make sure it is connected correctly. If the fault persists, contact Sungrow Customer Service.
	BMS and Battery Fault	If the fault persists after the device is restarted, please contact Sungrow Customer Service.
	Inversion open-loop self-test fault	If the fault still exists, please contact Sungrow Customer Service.
	Bus voltage unbalance	This fault is caused by a charge imbalance in the internal bus voltage of the machine. In general, the machine will start working normally again after a few minutes. If the fault recurs, please contact Sungrow Customer Service.
	Carrier Sync Fault	<ol style="list-style-type: none"> 1 Try to power down and reboot the device. 2 Check the carrier synchronization line to make sure that there are no loose connections. 3 If the fault is not caused by the foregoing reasons and still exists, contact Sungrow Customer Service.
	BMS and Battery Fault	If the fault persists after the device is restarted, please contact Sungrow Customer Service.
	N-wire current sampling channel failure	If the fault still exists, please contact Sungrow Customer Service.
	AC Incoming Line Phase Sequence Error	Please disconnect the external power supply to the PCS. Check whether the AC cabling are wrong in sequence or loose. If the fault still exists, please contact Sungrow Customer Service.

Type	Fault Name	Corrective measures
	Battery Current Sampling Abnormal	Check whether the battery current sampling cables are loose. If the problem persists, please contact SUNGROW Customer Service.
	AFCI Abnormal	Please contact Sungrow Customer Service.
	AFCI Fault	Please contact Sungrow Customer Service.
	Junction Box Temperature Fault	If the fault occurs repeatedly, please contact Sungrow Customer Service.
	Drain Valve Fault	Please contact Sungrow Customer Service.
	Mismatched Module Version	<ol style="list-style-type: none"> 1 Check whether the module type matches the current machine model. 2 If the fault is not caused by the foregoing reason, please contact Sungrow Customer Service.
	ARM and Main DSP Communication Fault	<ol style="list-style-type: none"> 1 Try to power down and restart the device. 2 Try to replace the ARM board. 3 If the fault is not caused by the foregoing reasons and still exists, please contact Sungrow Customer Service.
	AC Voltage Harmonic Abnormal	<ol style="list-style-type: none"> 1 Check whether the high-order voltage harmonics on the AC side exceed the limits. 2 If the limits are not exceeded, contact Sungrow Customer Service.
Alarm code 1	Low Insulation Impedance Alarm	<ol style="list-style-type: none"> 1 The machine can continue running. 2 Check the alarm-related cables and terminals for any abnormalities, check for any environmental abnormalities such as foreign objects, and clear the abnormalities. 3 If the alarm is not caused by the foregoing reasons and still persists, please contact Sungrow Customer Service.
	DC Contactor Abnormal	<ol style="list-style-type: none"> 1 The machine can continue running. 2 Check the alarm-related cables and terminals for any abnormalities, check for any environmental abnormalities such as foreign objects, and clear the abnormalities. 3 If the alarm is not caused by the foregoing reasons and still persists, please contact Sungrow Customer Service.

Type	Fault Name	Corrective measures
	GFRT Operation	<ol style="list-style-type: none"> 1 The machine can continue running. 2 Check the alarm-related cables and terminals for any abnormalities, check for any environmental abnormalities such as foreign objects, and clear the abnormalities. 3 If the alarm is not caused by the foregoing reasons and still persists, please contact Sungrow Customer Service.
	Charging Conditions Not Met	<p>Generally, the battery can automatically recover to normal. If the alarm persists for a long time:</p> <ol style="list-style-type: none"> 1 If overtemperature or low temperature actually exists, take heat dissipation measures to reduce the temperature. 2 If the alarm is not caused by the foregoing reasons and still exists, please contact the battery manufacture.
	Discharging Conditions Not Met	<p>Generally, the battery can automatically recover to normal. If the alarm persists for a long time:</p> <ol style="list-style-type: none"> 1 If overtemperature or low temperature actually exists, take heat dissipation measures to reduce the temperature. 2 If the alarm is not caused by the foregoing reasons and still exists, please contact the battery manufacture.
	BMS Internal Alarm	Consult battery manufacturer for a solution.
	Fan Alarm	Check the machine's fan. Please shut down the machine, disconnect the machine's power supply and remove any foreign objects. If the fan is damaged, please replace it.
	Voltage detection condition is not met before grid connection	Check whether the actual grid voltage and frequency satisfy the voltage detection conditions before grid connection set by APP.
	Ambient Temperature Sensor Open Circuit Alarm	<ol style="list-style-type: none"> 1 This is just an alarm upon which the inverter can run without risk. 2 Try power-off and restart of the inverter. 3 Again set DO2 power parameter. 4 if non-existence of above causes is confirmed and the fault remains , please contact the battery manufacture.

11.2 Maintenance

11.2.1 Routine Maintenance

Items	Methods	Period
System clean	Check the temperature and dust of the DC/AC power converter unit.	Six months to a year (it depends on the dust contents in air.)
	Clean the DC/AC power converter unit enclosure.	
	Check the humidity and dust of the environment. Meanwhile check whether the filter function of the air inlet is ok. Clean the air inlet and outlet, when necessary.	
Fans	Check whether there is crack of the fan blade.	Once a year
	Check whether there is any abnormal noise of the fan. Clean or replace the fans.	
Devices check	Check the fuses and the DC SPD.	Every 6 months
	Replace the fuse.	
	Contact SUNGROW to order new DC SPDs.	

11.2.2 Maintenance instructions

Wind turbine maintenance

There are three fans on the side of the PCS for active cooling during operation. If the fan is dirty or not working, the PCS may not cool down well and its efficiency may be reduced accordingly. Therefore, it is necessary to clean the dirty fan or replace the damaged one.



- Disconnect the PCS from the grid before carrying out any maintenance work and then disconnect it from the battery.
- There is still a lethal voltage in the PCS after the shutdown. Please wait at least 15 minutes before proceeding with maintenance work.
- The maintenance of the wind turbine should only be carried out by an electrician with the relevant qualifications.

Step 1 Disconnect the AC circuit breaker.

Step 2 Turn off the pre-amp DC circuit breaker. Rotate the BAT switch on the side of the PCS to the "OFF" position.

- Step 3** Wait at least 30 minutes.
- Step 4** Follow the reverse steps in Chapter 6 Electrical Connections to disconnect all electrical connections.
- Step 5** Multiple people are required to work together to lift the PCS off the stand and then remove it from the wall.
- Step 6** Place the PCS on the platform.
- Step 7** Unscrew the screws of the fan.
- Step 8** Use your finger to pick the groove on the side of the PCS (the screw near the fan) and pull out the slot of the fan.
- Step 9** Press down on the raised position of the latch hook and unplug the cable connector outward.
- Step 10** Remove the fan from the PCS.
- Step 11** Dirty fans can be cleaned using a soft brush or vacuum. or replace the damaged fan.
- Step 12** Reassemble the fan onto the PCS.
- Step 13** Connect the four connectors and secure them with cable ties.
- Step 14** The board is assembled by fixing two screws on both sides.
- Step 15** Perform electrical and mechanical connections and restart the PCS.

-- End

Clean the air inlet and outlet

A large amount of heat is generated during the operation of the PCS. The PCS uses a controlled forced air cooling method.

To maintain good ventilation, check to see if anything is blocking the air inlets and outlets.

If necessary, clean the air inlet and outlet with a soft brush or vacuum.

12 Appendix

12.1 Technical Data

Type designation	SC100CX	SC110CX	SC125CX
DC side			
Max. DC voltage		1000 V	
DC voltage range		600–1000 V	
Max. DC current	187.1 A	205.8 A	212.5 A
AC side (Grid)			
AC output power	100 KW	110 KW	125 KW
Converter port nominal AC voltage	AC 3L/N/PE 220/380,230/400V		
Nominal grid frequency	50 / 60Hz		
Max. AC apparent power	110 kVA	121 kVA	137.5 kVA
Converter port max. AC output current	167.1 A	183.8 A	208.9 A
Adjustable power factor	1 leading - 1 lagging		
General Data			
Dimensions (W * H * D)*	820*1019*310 mm (with hands)		
Weight*	100±10 kg		
Security level	Type I		
Overvoltage rating	Type III (AC) 、 Type II (DC)		
Degree of protection	IP66		
Operating ambient temperature range	-30°C~60°C(>45°C derating)		
Non-isolated PCS	YES		
Compliance	GB/T 34120 、 IEC 62477-1		

*The illustration is for reference only, and the actual product shall prevail.

12.2 Tightening Torques

Tighten the cable with proper torque shown below to prevent the poor contact, high contact resistance, or fire caused by the looseness of cable lugs:

Screw size	Torque(N.m)	Torque(lbf.inch)
M3	0.7~1	6.195~8.85
M4	1.8~2.4	15.93~21.24
M5	4~4.8	35.4~42.48
M6	7~8	61.95~70.8
M8	18~23	159.3~203.55
M10	34~40	300.9~354
M12	60~70	531~619.5
M16	119~140	1053.15~1239

The above cables are not included in the scope of supply and need to be prepared separately.

12.3 Quality Assurance

When product faults occur during the warranty period, SUNGROW will provide free service or replace the product with a new one.

Evidence

During the warranty period, the customer shall provide the product purchase invoice and date. In addition, the trademark on the product shall be undamaged and legible. Otherwise, SUNGROW has the right to refuse to honor the quality guarantee.

Conditions

- After replacement, unqualified products shall be processed by SUNGROW.
- The customer shall give SUNGROW a reasonable period to repair the faulty device.

Exclusion of Liability

In the following circumstances, SUNGROW has the right to refuse to honor the quality guarantee:

- The free warranty period for the whole machine/components has expired.
- The device is damaged during transport.
- The device is incorrectly installed, refitted, or used.
- The device operates in harsh conditions beyond those described in this manual.
- The fault or damage is caused by installation, repairs, modification, or disassembly performed by a service provider or personnel not from SUNGROW.

- The fault or damage is caused by the use of non-standard or non-SUNGROW components or software.
- The installation and use range are beyond stipulations of relevant international standards.
- The damage is caused by unexpected natural factors.

For faulty products in any of above cases, if the customer requests maintenance, paid maintenance service may be provided based on the judgment of SUNGROW.



Product data such as product dimensions are subject to change without prior notice. The latest documentation from SUNGROW should take precedence in case of any deviation.

12.4 Contact Information

In case of questions about this product, please contact us. We need the following information to provide you the best assistance:

- Model of the device
- Serial number of the device
- Fault code/name
- Brief description of the problem

For detailed contact information, please visit: <https://en.SUNGROWpower.com/contactUS>

SUNGROW

Sungrow Power Supply Co., Ltd.
www.sungrowpower.com