

PowerStack C&I Liquid-Cooled Energy Storage System

Quick Installation Guide

ST255CS-2H-IEC



- This document will be updated from time to time due to updates of the product or other reasons. Under no circumstances should this document be taken as a substitute for the user manual and the safety instructions provided on the product.
- Before performing any operation, please read through carefully the user manual and relevant standards and specifications. You can find the related documents by visiting <http://support.sungrowpower.com/> or by scanning the QR code provided on the product or the back cover of this Quick Installation Guide.
- Operations on the equipment must only be performed by qualified technical persons. The qualified technical persons must have received specialized training, read through the user manual to gain a good understanding of the relevant safe operation instructions, and be familiar with the applicable local standards and safety code for electrical systems.
- Before installation, check the delivered items for quantity according to the packing list and see if the delivery matches the order you placed. Meanwhile, inspect the items for any visible damage. Contact the transport service provider or SUNGROW in case of anything abnormal.
- The cables used for the energy storage system must all be intact and well-insulated. Be sure to use insulated tools and wear personal protective equipment properly during operation.
- Violation of any of the above requirements may result in personal injury or equipment damage.
- This guide covers two types of products: the battery container and the transformer cabinet. Information related to the transformer cabinet does not apply to grid-connected applications.

Safety Disclaimer

SUNGROW shall not be held liable for any personal injury or equipment damage arising from equipment-related operations that are not carried out in compliance with the requirements specified in this document or the user manual.

DANGER

- Danger of electric shocks!
- Hazardous voltages will be generated in the product when it is exposed to sunlight!
- Electrical connections must only be performed by qualified technical persons.
- Electrical connections must be done in compliance with the applicable local and national electrical standards.
- The energy storage system can only be connected to the grid with approval from the local electricity department.
- Ensure that the cabinet is intact and closed to maintain both personal and property safety. Do not open the cabinet while the energy storage system is operating or carries voltage. SUNGROW shall not be held liable for consequences resulting from failure to follow this instruction.
- Opening the cabinet exposes personnel to the risk of contact with the internal live components, which could result in severe electric shock, personal injury, or even death.

WARNING

All safety instructions, warning labels, and nameplate on the energy storage system must be clearly visible and cannot be removed or covered.

CAUTION

Burn hazard!

- Do not touch any hot part of the energy storage system while it is operating (such as heat sink).

NOTICE

Parameters of the energy storage system, such as country (region) and protection parameters, must be configured by qualified technical personnel in compliance with local grid standards. Incorrect country (region) settings may affect the normal operation of the energy storage system and result in non-compliance with local certification requirements.

Signs on the Product



Temperature beyond the acceptable range for human body. Do not touch; otherwise, it may lead to injuries.



Danger! Do not work on the product when it carries voltage.



Danger of death due to high voltage!
After the equipment is disconnected from the external power source, wait at least 15 minutes before touching any of its internal conductive parts.



Beware of heavy weights! Lifting the heavy object directly may cause back injury. Please lift it with the assistance of proper tools.



Beware of explosion.



Beware of corrosion.



Do not dispose of it together with household waste.



No fires.



A nearby medical facility must be set up.



If it gets in your eyes, flush you eyes immediately with running water or saline, and seek medical advice in time.



Protective Earthing (PE) terminal. This terminal must be connected for reliable grounding to ensure the safety of the operator.



Read the manual before performing any operation on the product.



Wear safety goggles.



The product is recyclable.



The lithium battery is recyclable.

Installation Tools



Phillips/Slotted torque screwdriver



Socket wrench



Wire strippers



Wire cutter

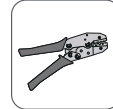

Crimping tool



Rubber mallet



Utility knife



Hydraulic pliers



Torque wrench



Marker

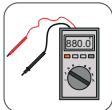

Multimeter



Hammer drill



Heat shrink tubing

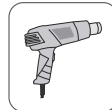

Heat gun



Vacuum cleaner



Powered forklift



Crane

Personal Protective Equipment



Safety gloves



Safety goggles



Safety shoes



Protective clothing



Dust mask



Safety helmet



Reflective vest



Safety harness for working at heights

Electrical Safety Equipment



Rescue pole



Anti-static wristband



Insulated gloves



Insulated stool

- The above figures are for reference only and may deviate from the actual product.

NOTICE

The tools listed above may not encompass all necessary tools, as requirements can vary based on installation site conditions. Installers and users should prepare additional tools as needed to suit their specific circumstances.

External Design and Dimensions

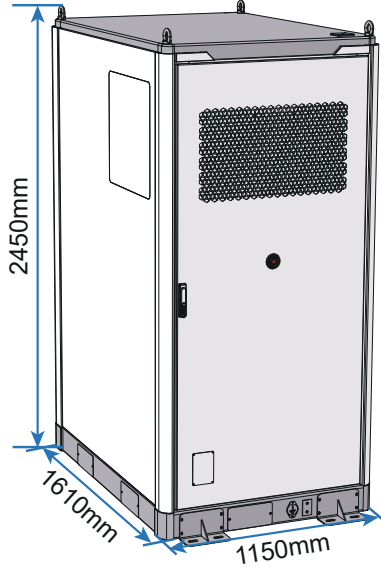

Internal Structure

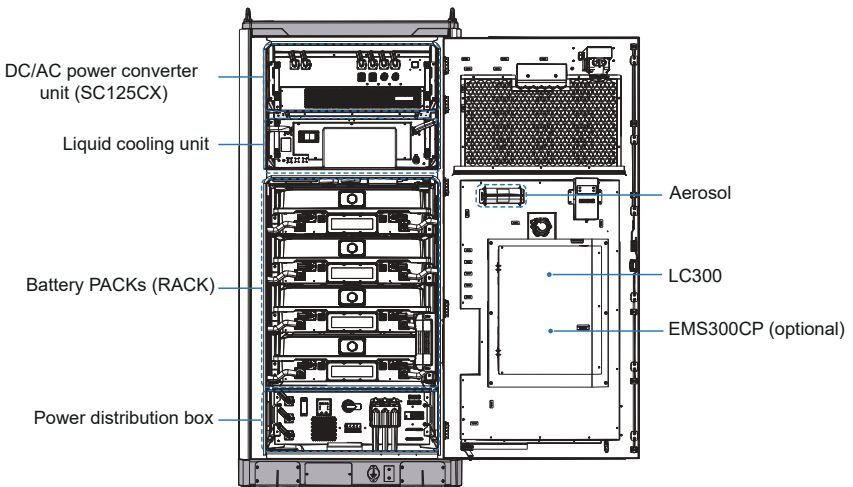

Energy Storage System Transportation

Option 1: Hoisting

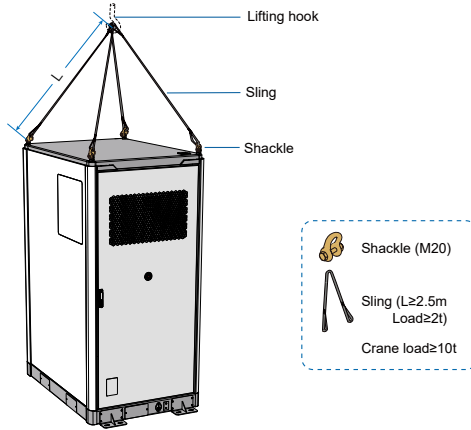

Option 2: Forklift handling

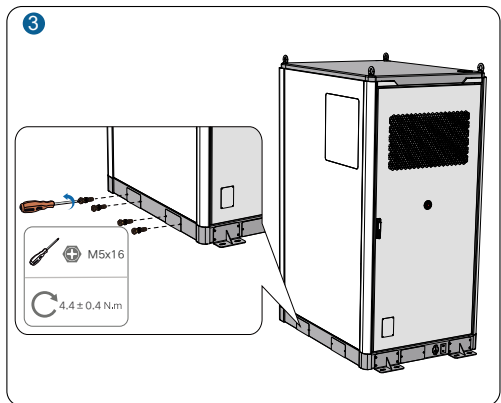
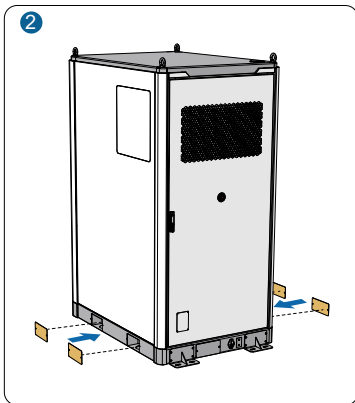
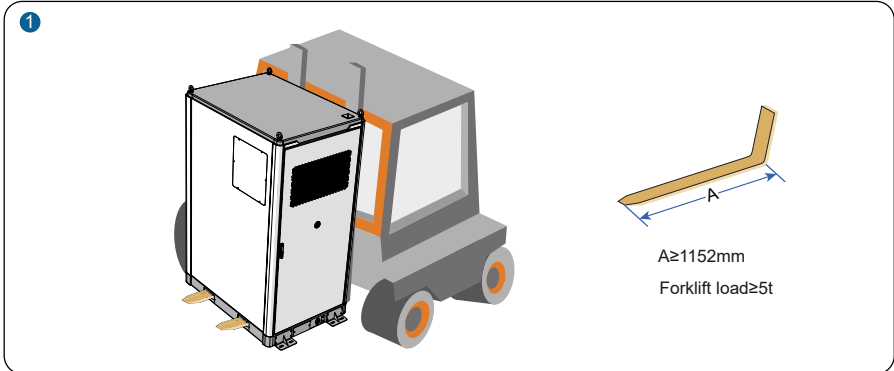

Energy Storage System Securing

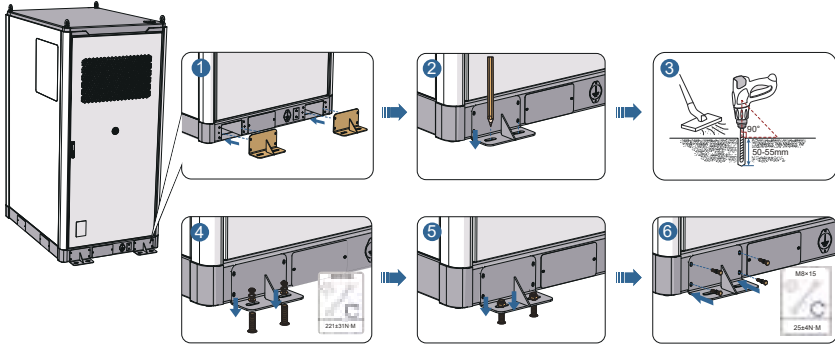

Cable Requirements

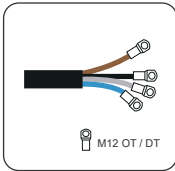

1 AC cable of the energy storage system

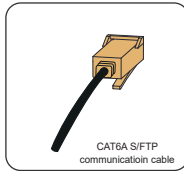

2 Communication cable

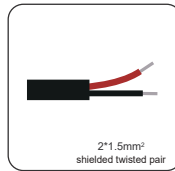

3 Shielded twisted pair

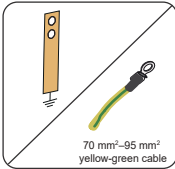

4 Grounding copper bar/cable

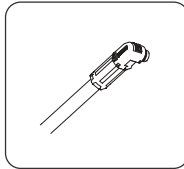

5 Battery power cable

External Grounding of Energy Storage System

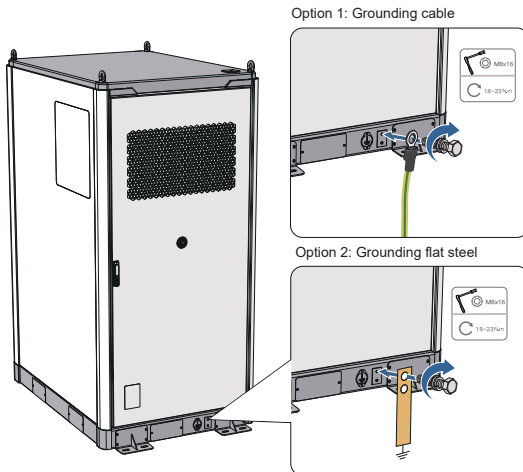

Option 1: Grounding cable

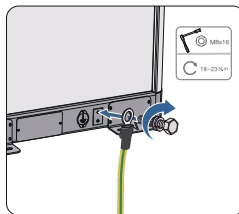

Option 2: Grounding flat steel

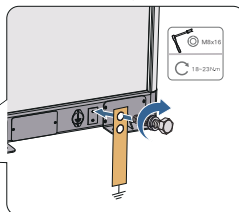

AC and Internal Equipotential Bonding of Energy Storage System

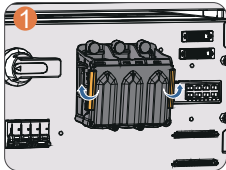
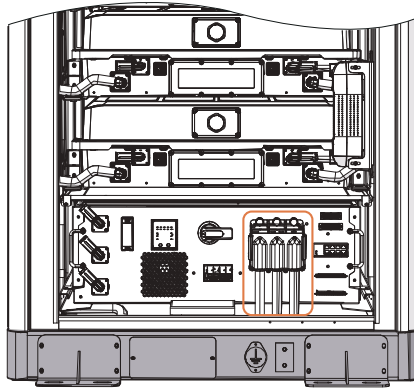

1 Release the snap-fits on the junction box

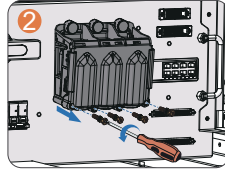

2 Remove the screws from the box

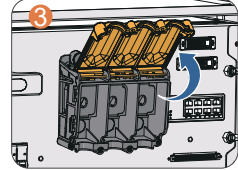

3 Open the box cover

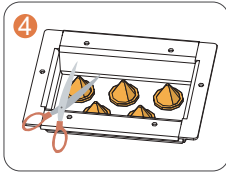

4 Trim the cone-shaped grommets

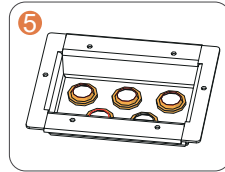

5 Ensure the sizes of the openings are appropriate

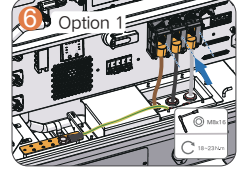

6-1 AC and equipotential bonding scheme 1

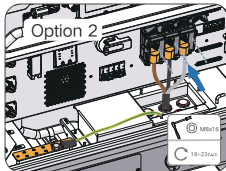

6-2 AC and equipotential bonding scheme 2

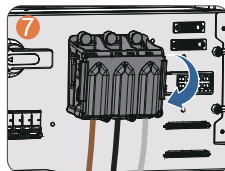

7 Close the box cover

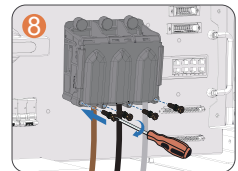

8 Secure the snap-fits and tighten the screws

EMS300CP Installation

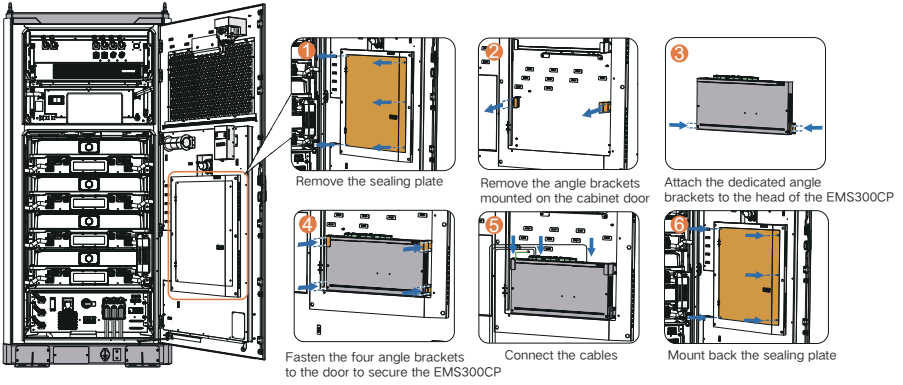

EMS300CP Wiring

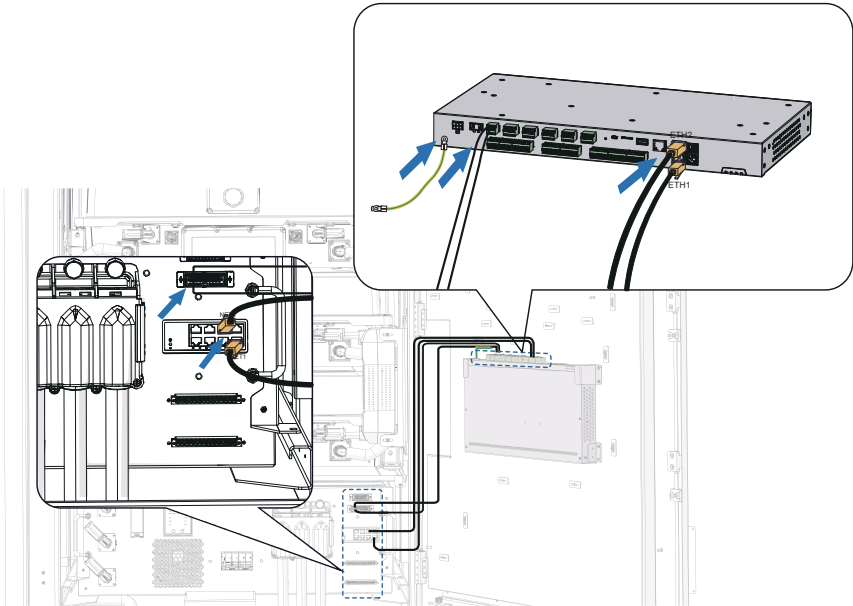

Meter Communication Wiring

Determine the number of RS485 cables required between the battery container and the meter based on the specific EMS300CP solution implemented on-site.

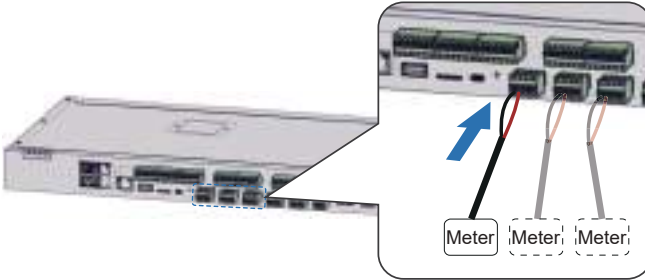

Ethernet Wiring

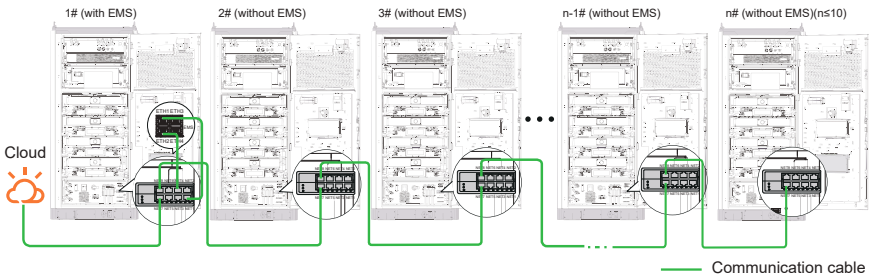

NOTICE

The system supports up to 10 ESSs in parallel. The cabinet with an EMS is accessed to the customer network and connected hand-in-hand with other ESSs that do not have EMS.

Sealing with Fireproof Mud

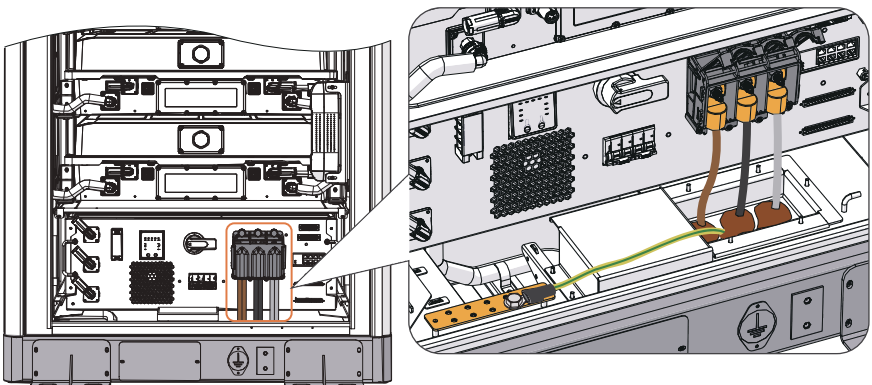

Battery Power Cable Connection



Before connecting the power cables, put on insulated shoes and safety gloves.

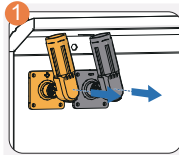

1 Remove the DC-side cable connectors of the DC/AC power converter unit

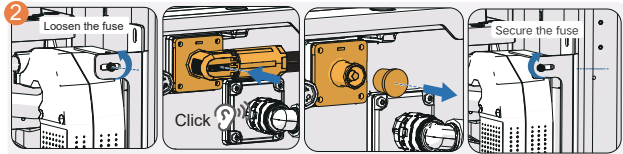

2-1 Loosen the fuse bolt so that the fuse can freely move
2-2 Attach the battery cable connector
2-3 Remove the plug
2-4 Secure the fuse bolt

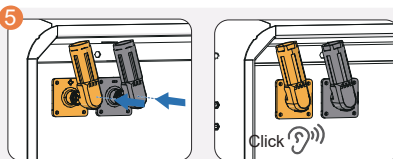
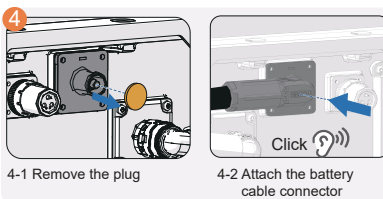
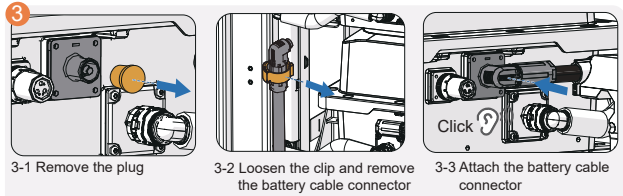

5 Attach the DC-side cable connectors of the DC/AC power converter unit

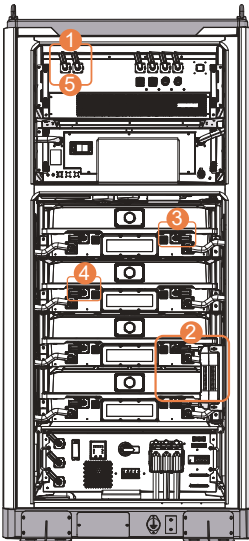

Inspection Before Powering on

No.	Inspection item	Requirements
1	Equipment exterior	<ul style="list-style-type: none"> <input type="checkbox"/> Verify the equipment model and technical data against the nameplate. <input type="checkbox"/> Ensure the equipment is in good condition, free from damage, rust, or paint peeling. If paint peeling is observed, repair the affected areas promptly. <input type="checkbox"/> Confirm that labels are clearly visible; replace any damaged labels as needed.
2	Cable exterior	<ul style="list-style-type: none"> <input type="checkbox"/> Ensure the protective layers of the cables are intact and free from visible damage. <input type="checkbox"/> Ensure the cable hoses are intact.
3	Cable connection	<ul style="list-style-type: none"> <input type="checkbox"/> Ensure the cables are connected to the designated positions as outlined in the design. <input type="checkbox"/> Ensure the terminals are prepared according to the requirements and securely connected. <input type="checkbox"/> Ensure the labels on both ends of each cable are clear and consistent in orientation.
4	Cable arrangement	<ul style="list-style-type: none"> <input type="checkbox"/> Ensure the low-voltage and high-voltage cables are routed separately. <input type="checkbox"/> Ensure the cables are well organized. <input type="checkbox"/> Ensure the cable tie joints are cleanly cut without any burrs. <input type="checkbox"/> Ensure the cables have sufficient slack at bends as required. Do not tighten the cables excessively. <input type="checkbox"/> Ensure the cables are laid neatly, without twists or crossing in the cabinet.
5	Switch	<ul style="list-style-type: none"> <input type="checkbox"/> Verify that AC and DC load switches are in the OFF state.

System Start-up

NOTICE

Ensure the outdoor temperature is between $-30\text{ }^{\circ}\text{C}$ and $50\text{ }^{\circ}\text{C}$.

It is not recommended to power on at temperatures below $-30\text{ }^{\circ}\text{C}$. If the temperature is too low, it will take 24 consecutive hours or more for the system to heat the cells. During this period, the system cannot operate normally.

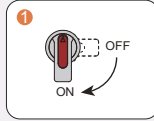
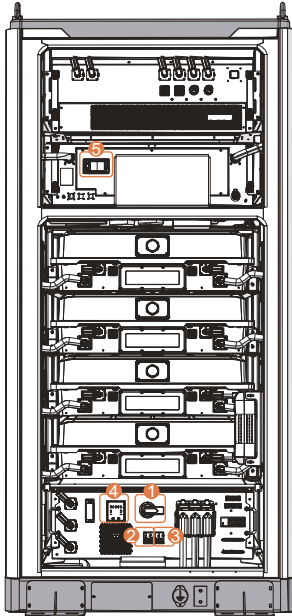

Turn on the AC main switch

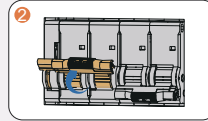

Turn on the AC auxiliary switch

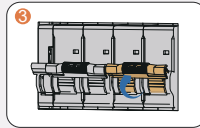

Turn on the UPS switch

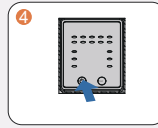

Press the UPS power button

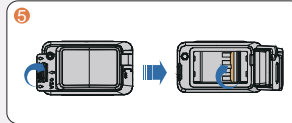

Open the cover of the liquid cooling unit
Turn on the liquid cooling unit switch

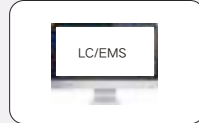

Start up the system via the control software

System Shutdown

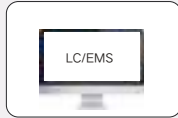
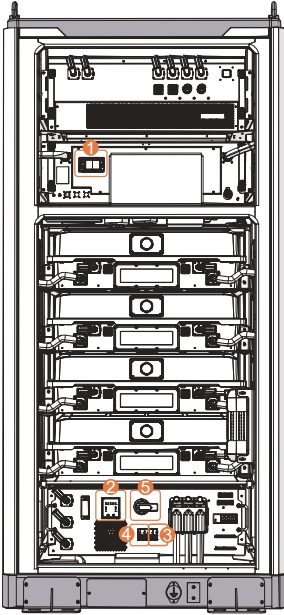

Shut down the system via the control software

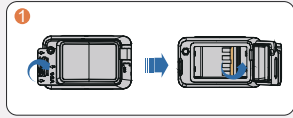

Open the cover of the liquid cooling unit
Turn off the liquid cooling unit switch

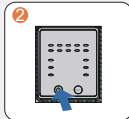

Turn off the UPS power

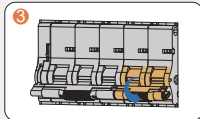

Turn off the UPS switch

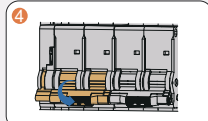

Turn off the AC auxiliary switch

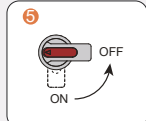

Turn off the AC main switch



More information in the QR code or
at <http://support.sungrowpower.com>